

## Data sheet

### MB-DIO2/1-IP Modbus/BACnet 24V AC/DC

## Illustrations



Wiring diagram

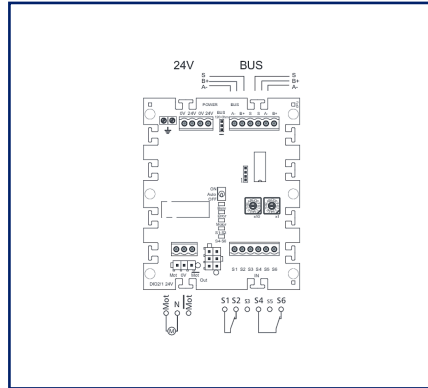

Principle diagram

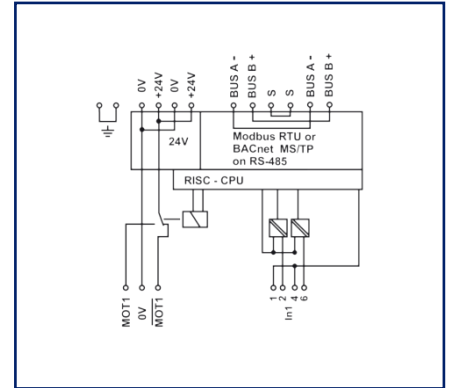

See enlarged drawings at the end of document

## Product specification

The MB-DIO2/1-IP 24 V module in IP65 housing with 2 digital inputs, as well as 1 relay output, is suitable for the inclusion of decentralized signal contacts and the control of decentralized switching tasks. As signal contacts, e.g. window contacts or the positions of ventilation flaps, etc. can be detected and controlled for switching tasks, e.g. motorized actuators or light bands, etc. Actuators with AMP connectors (AMP brand from TE Connectivity) can be connected directly to the MB-DIO2/1-IP 24 V. Depending on the operating mode, the module can be switched or requested with Modbus standard registers or with BACnet objects.

- for the control of an actuator, e.g. fire damper
- Connection options for actuators with AMP plug-in connector or open connection lines with pluggable push-in technology
- Supply voltage is also switching voltage
- Relay output suitable for inrush current 65 A < 20 ms (NO), continuous current 6A
- generous space for installation - no additional distribution box required

## Technical Data

### Approvals



BACnet is a registered trademark of ASHRAE. ASHRAE does not endorse, approve or test products for compliance with ASHRAE standards. Compliance of listed products to the requirements of ASHRAE Standard 135 is the responsibility of BACnet International (BI). BTL is a registered trademark of BI.

### RS485 interface

Protocol	Modbus RTU / BACnet MS/TP
Address range	00 - EF
Bus interface	RS485 two wire bus with potential equalization in bus or line topology, terminate with 120 Ohm
Transmission parameters	
Transmission rate	min. 1200 Bit/s (Bd) - max. 115200 Bit/s (Bd)
Transmission rate default setting	19200 Bit/s (Bd)
Parity	None, Even (default setting), Odd
Stopbits	1 (default setting), 2

### Supply

Operating voltage	24 V AC/DC +/- 10 % (SELV)
Duty cycle relative	100 %

### Inputs

Digital inputs	2
----------------	---

### Outputs

Digital outputs	1
Relay output	2 changeover contacts
Switching voltage relay output (max.)	24 V AC
Continuous current relay output	6 A / relay
Switch-on current relay output (max.)	65 A < 20 ms (NO)
Total current across all outputs	6 A
Mechanical life	10x10 <sup>6</sup> switching cycles
Electrical life	10x10 <sup>4</sup> switching cycles

### Technical Data

Insulation coil - contact set	
Nominal voltage of the power supply system	24V AC/DC = Operating voltage
Overvoltage category	III   II
Degree of pollution	2   2
Rated test voltage	4 kV   2.5 kV
Type of insulation	basic insulation   reinforced insulation
Housing	
Dimensions	
Dimension (W x H x D)	125 mm x 75 mm x 175 mm
Dimension (W x H x D)	4.921 in. x 2.953 in. x 6.89 in.
Weight	460.9 g
Mounting style	directly on a flat base, knock-out openings for screw connections 4 x M16/25 + 8 x M12/20
Mounting position	any
Indicator	green, red and yellow LED
Terminal blocks	
Connection type 1	
Pluggable spring clamp terminal block	
Terminal block (bus)	6-pole
Terminal block (motor)	3-pole
Connection terminal (digital inputs, potential-free limit switches)	6-pole
Solid wire (AWG)	max. 12 AWG
Stranded wire (mm <sup>2</sup> )	max. 2.5 mm <sup>2</sup>
Stranded wire (AWG)	max. 12 AWG
Wire diameter	max. 2.5 mm
Wire cross section solid	0.2 mm <sup>2</sup> - 2.5 mm <sup>2</sup> / AWG 22-12
Wire cross section multi	0.2 mm <sup>2</sup> - 2.5 mm <sup>2</sup> / AWG 22-12
Wire cross section with wire ferrule	0.2 mm <sup>2</sup> - 2.5 mm <sup>2</sup> / AWG 22-12
Stripping length (min.)	10 mm
Connection type 2	
AMP pin header (Mate-N-Lok)	
Pin header connection (motor)	3-pole (TE Connectivity 1-770170-1)
Pin header connection (digital inputs, potential-free limit switches)	6-pole (TE Connectivity 1-770178-1)
Hinged cable glands	e.g. KVT 20 with cable grommets KT 6 (6 mm) and KT 8 (8mm) from icotek (R)

## Technical Data

### Terminal blocks

Connection type 3	screw type terminal block
Terminal block (protective conductor)	2x 1-pole
Wire cross section solid	0.2 mm <sup>2</sup> - 1.5 mm <sup>2</sup> / AWG 22-16
Wire cross section multi	0.2 mm <sup>2</sup> - 1.5 mm <sup>2</sup> / AWG 22-18
Wire cross section with wire ferrule	0.2 mm <sup>2</sup> - 1.5 mm <sup>2</sup> / AWG 22-18
Screw torque (max.)	0.5 Nm
Stripping length (min.)	6 mm
Protection circuit	Polarity reversal protection for DC operating voltage

### Material

Material - Housing	Polycarbonat
Color	gray
Material - Terminal block	Polyamid 6.6 V0

### Protection category according to IEC 60529

Protection category - housing (acc. to IEC 60529)	IP66 / IP67 (without screw fittings)
Protection category - terminal blocks (acc. to IEC 60529)	IP20

### Temperature range

Operating	
Temperature - Operating °C	-5 °C - 55 °C
Temperature - Operating °F	23 °F - 131 °F
Storage	
Temperature - Storage °C	-20 °C - 70 °C
Temperature - Storage °F	-4 °F - 158 °F

### Classifications

ETIM 7.0	EC001584
ETIM 8.0	EC001584
ETIM 9.0	EC001584

# C | Logline

Data sheet

**MB-DIO2/1-IP Modbus/BACnet 24V AC/DC**

Page 5/7

P/N

1108111326IP

EAN 4251394658346

2023/06/23

Version: C

## Technical Data

### Software and additional documents

Software and documentation

Further documentation is available for free download at [www.metz-connect.com](http://www.metz-connect.com)



**Accessories**

P/N	Designation
110561	Power supply NG4 24 V DC
11056170	Power supply NG4-F 24 V DC
11083001	MR-GW Modbus RTU / Modbus TCP Gateway
1108300170	MR-F-GW Modbus RTU / Modbus TCP Gateway
11088001	BMT-RTR BACnet-Router
1108800170	BMT-F-RTR BACnet-Router

**Illustrations**

Wiring diagram

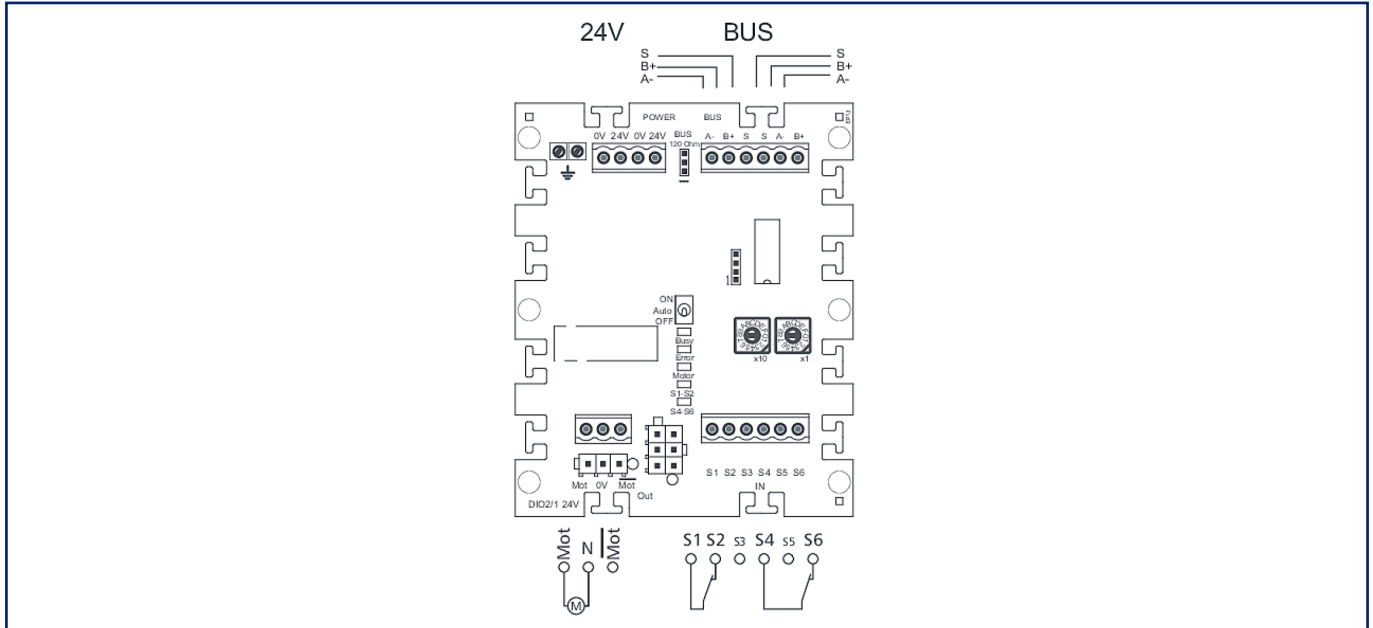

Principle diagram

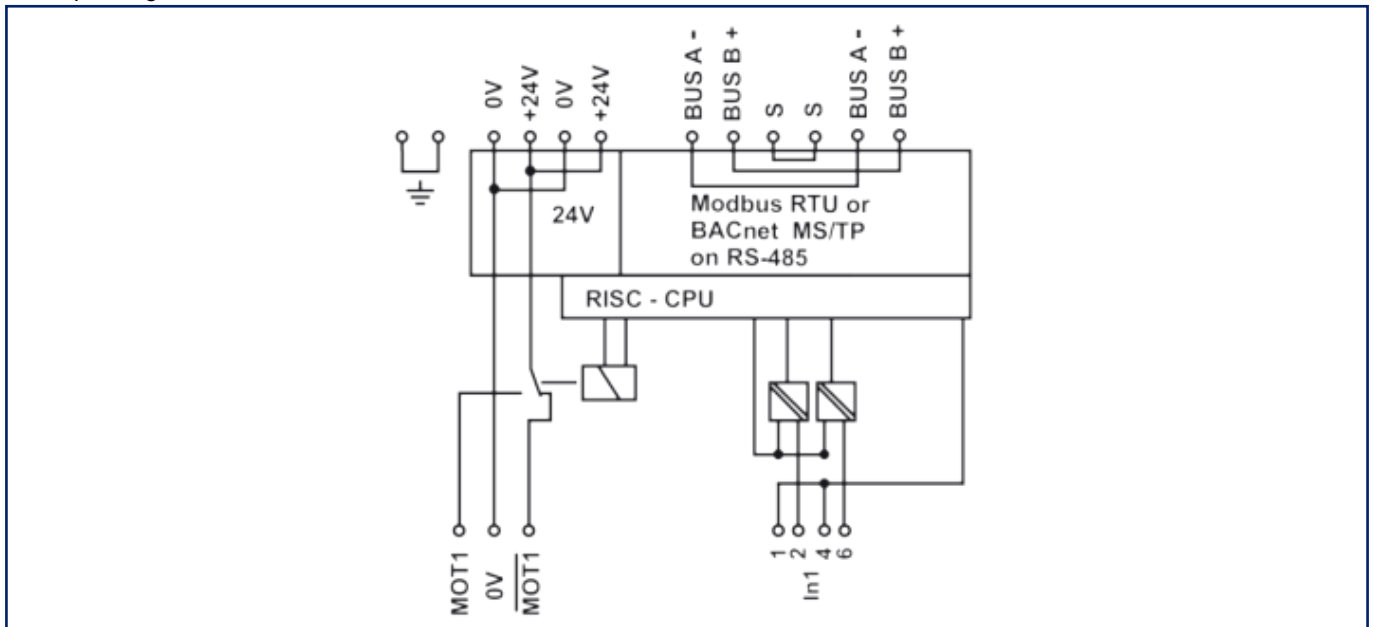

© 2023 METZ CONNECT - Technische Änderungen vorbehalten! Subject to modifications! Sous réserve de modifications techniques!