

Data sheet

OpDAT adapter E2000-Duplex OS2 with Snap-In mounting

Page 1/5

P/N
1509005B-I

EAN 4250184149439

2023/04/06

Version: T

Illustrations

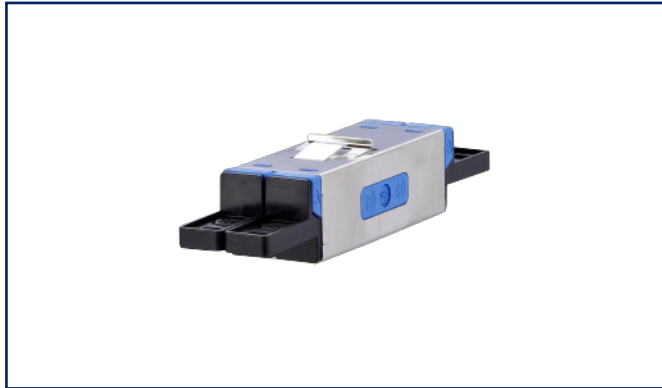

Dimensional drawing

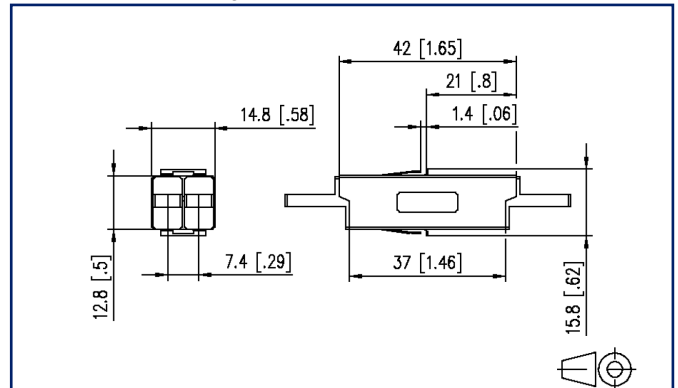

See enlarged drawings at the end of document

Product specification

- housing of the E2000 DC (duplex compact) adapter made of plastic
- slotted sleeve made of ceramics
- high material stability and surface quality and long service life
- service life: min. 1000 plug cycles
- snap-in mounting
- variants: blue (SM), green (SM APC), beige (MM)



OpDAT adapter E2000-Duplex OS2 with Snap-In mounting

P/N
1509005B-I

EAN 4250184149439

2023/04/06

Version: T

Technical Data

General Data

Fields of application	structured building cabling fiber to the desk data center
Mechanical measurement according to MICE	M1
Ingress measurement according to MICE	I1
Climatic measurement according to MICE	C1
Electromagnetic measurement according to MICE	E3
Design	coupler / adapter (FO)
Transmission technology	Fiber optic
Color	blue
Dimensions	
Dimension (L x W x H)	42 mm x 13 mm x 9.2 mm
Dimension (L x W x H)	1.654 in. x 0.512 in. x 0.362 in.
Mode type of the fiber	Singlemode
Shape	UPC (Ultra Physical Contact)
Labeling option	on housing

Connections/interfaces

Connector technology interface 1	E2000-D
Connector technology interface 2	E2000-D
Number of ports interface 1	2
Number of ports interface 2	2
Number of equipped ports interface 1	2
Number of ports interface 2 equipped	2
Number of ports with dust protection interface 1	2
Number of ports with dust protection interface 2	2

Mechanical data

Cut-out	E2000-D
Connector type	duplex
Mounting method	snap-in function
Life - Number of mating cycles	min. 1000
Position/mounting of latch standard installation position	top

OpDAT adapter E2000-Duplex OS2 with Snap-In mounting

P/N
1509005B-I

EAN 4250184149439

2023/04/06

Version: T

Technical Data

Materials and material properties

Material - Housing	Plastics
Material - Sleeve	ceramic, slotted
Halogen free	yes
RoHS	compliant

Standards/Regulations

Fibre optic connector interfaces	IEC 61754-15
----------------------------------	--------------

Classifications

ETIM 5.0	EC000752
ETIM 6.0	EC000752
ETIM 7.0	EC000752
ETIM 8.0	EC000752
ETIM 9.0	EC000752

Packing details

Type of packaging	1 pc(s) / plastic bag
Packaging unit - Weight (gram)	20 g
Packaging unit - Weight (pound)	0.04 lb
Packaging dimension	380 mm x 160 mm x 100 mm
Packaging dimension	14.961 in. x 6.299 in. x 3.937 in.

P | Cabling

Data sheet

Page 4/5

OpDAT adapter E2000-Duplex OS2 with Snap-In mounting

P/N
1509005B-I

EAN 4250184149439

2023/04/06

Version: T

Accessories from

P/N	Designation
1309426103-E	E-DAT modul REG unequipped IP20 light gray
1309427103-E	Modul REGplus IP20 light gray unequipped
1309428103-E	Keystone REGplus IP20 light gray unequipped
14040000-E	MCO IP69k protective housing for outdoor use, set for exposed installation
14040010-E	MCO IP69k Protective housing for outdoor use, set with mounting bracket
14040100-E	MCO IP69k Protective housing for outdoor use, set wall/ housing bushing
15024A5A00-E	OpDAT REGpro front cover for 6xE2000-Duplex Snap-In
15036Z5F00-E	OpDAT MV patch panel 9xE2000-D unequipped



P | Cabling

Data sheet

Page 5/5

OpDAT adapter E2000-Duplex OS2 with Snap-In mounting

P/N

1509005B-I

EAN 4250184149439

2023/04/06

Version: T

Illustrations

Dimensional drawing

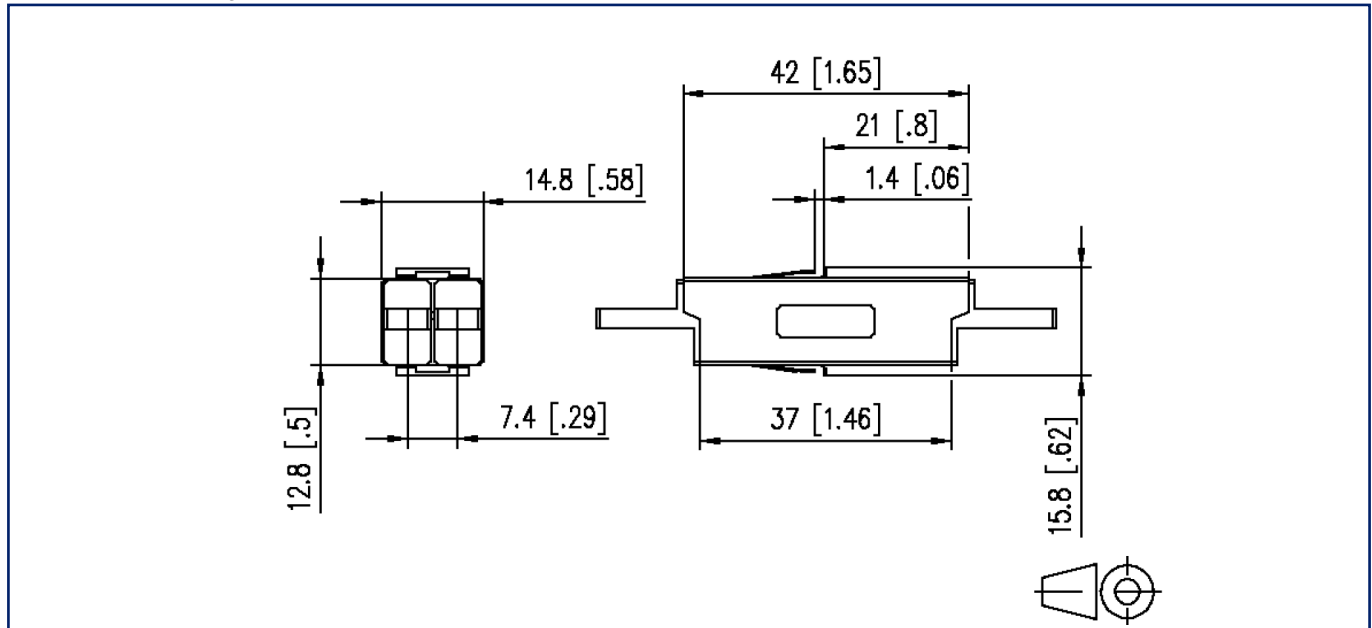

© 2023 METZ CONNECT - Technische Änderungen vorbehalten! Subject to modifications! Sous réserve de modifications techniques!