

**Illustrations**

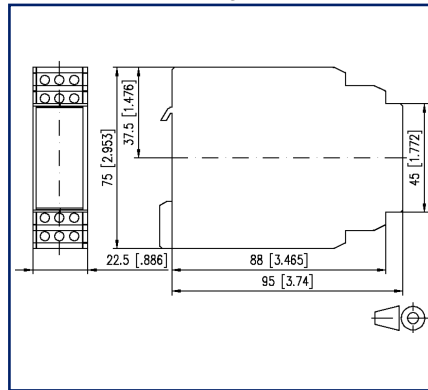

Dimensional drawing



Wiring diagram

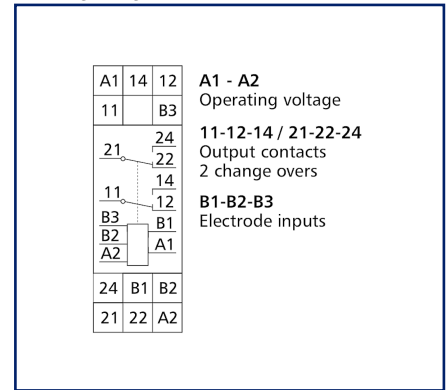

See enlarged drawings at the end of document

**Product specification**

The level sensor monitors filling levels or leakage of all conductive, noncombustible media. The trigger can be adjusted by means of a proportional potentiometer. As monitor, the device works with an electrode (EO) and the ground connection (EM), e.g. for minimum and maximum levels, to protect submersible pumps from overflowing or running dry. If the surface of the fluid is subject to disturbance, we recommend another electrode (EU). As two-level controller, the device controls pumps or valves for automatically filling and emptying containers by means of the EO and EU electrodes and the EM ground connection. A container wall, being conductive to the medium, can also be used as ground connection. With 2 electrodes connected the contacts B2 and B3 must be connected with a bridge! Variant: 230 V AC

## Technical Data

<b>Supply</b>	
Operating voltage	230 V AC -10% ... +10%
Frequency range	50 ... 60 Hz
Duty cycle relative	100 %
Recovery time	>= 250 ms
<b>Inputs</b>	
Response delay	5 - 50 kOhm, adjustable
Release time typical	20 ms
Shutter release delay	<= +/- 0.01 %
<b>Outputs</b>	
Contacts	2 changeover contacts
Contact material	AgSnO <sub>2</sub>
Switching voltage (max.)	250 V
Continuous Current	6 A
Switch-off delay	230 V~ 6 A AC1, 230 V~ 3 A AC3, 230 V~ 0,12 A, 60 V~ 0,6 A, 24 V~ 3 A, 12 V~ 4 A DC1
Switching frequency	600 switching cycles/h
Mechanical life	3x10 <sup>7</sup> switching cycles
Electrical life	2x10 <sup>5</sup> switching cycles
Indicator	green LED
<b>Housing</b>	
Dimensions	
Dimension (W x H x D)	22.5 mm x 75 mm x 95 mm
Dimension (W x H x D)	0.886 in. x 2.953 in. x 3.74 in.
Weight	300 g
Mounting style	Standard rail TH35
Mounting position	any
Apposition	without distance
Connection type	Screw type terminal blocks

## Technical Data

### Terminal blocks

Wire cross section solid	0.2 mm <sup>2</sup> - 2.5 mm <sup>2</sup> / AWG 22-12
Wire cross section multi	0.25 mm <sup>2</sup> - 2.5 mm <sup>2</sup> / AWG 22-12
Wire cross section with wire ferrule	0.25 mm <sup>2</sup> - 2.5 mm <sup>2</sup> / AWG 22-12
Screw torque (max.)	0.5 Nm
Stripping length (min.)	8 mm

### Material

Material - Housing	Polyamid 6.6 V0
Color	gray
Material - Terminal block	Polyamid 6.6 V0
Material - Covers	Polyamid 6.6 V0

### Protection category according to IEC 60529

Protection category - housing (acc. to IEC 60529)	IP40
Protection category - terminal blocks (acc. to IEC 60529)	IP20

### Temperature range

Operating	
Temperature - Operating °C	0 °C - 55 °C
Temperature - Operating °F	32 °F - 131 °F
Storage	
Temperature - Storage °C	-20 °C - 70 °C
Temperature - Storage °F	-4 °F - 158 °F

### Power loss

Power loss (typical) coil	2 W
Power loss (typical) Contact rate	500 mW

### Classifications

ETIM 7.0	EC001447
ETIM 8.0	EC001447
ETIM 9.0	EC001447

## Accessories

P/N	Designation
11032401	Submersible electrode TE2
110329	Leakage sensor LKS1
11032901	Leakage sensor LKS1 brown



## Illustrations

Dimensional drawing

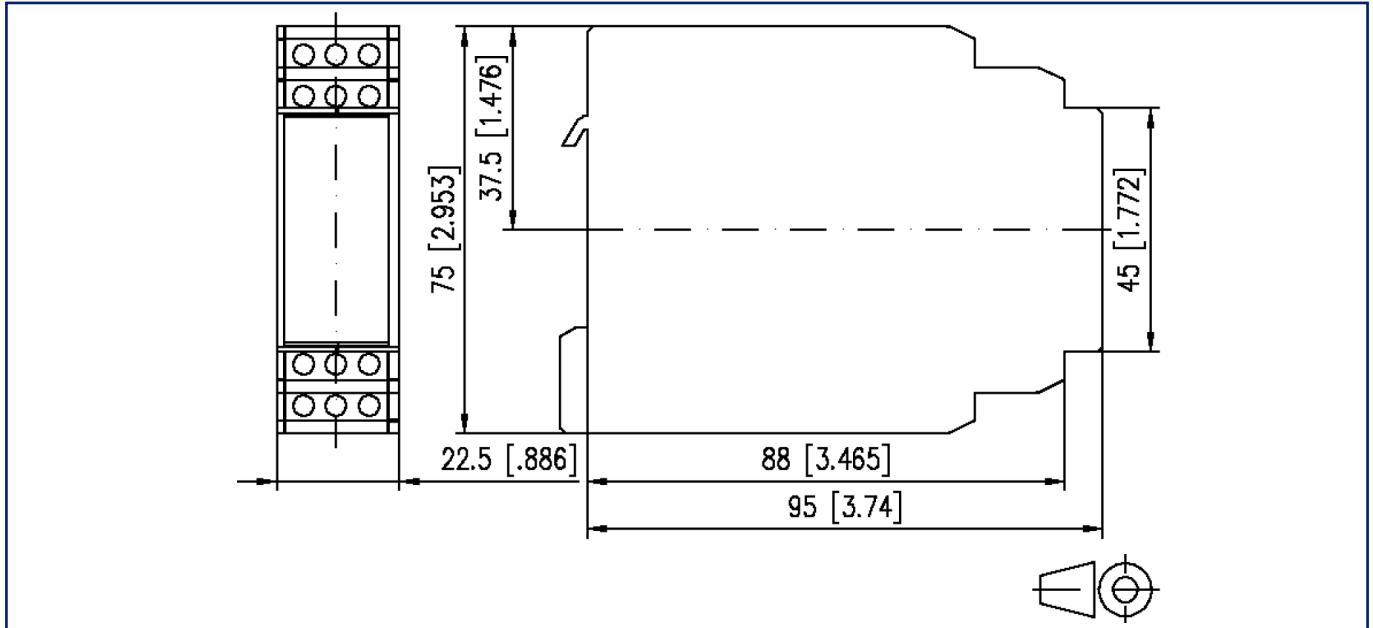

Wiring diagram

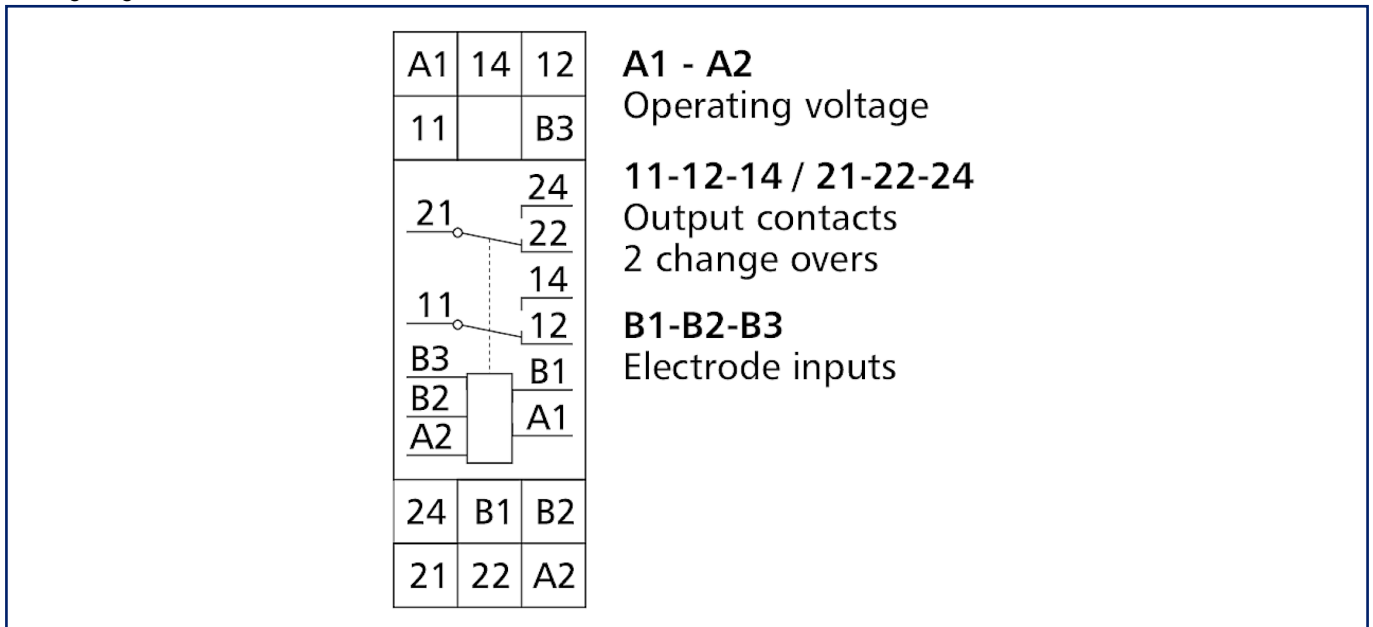

## Illustrations

### Connection example

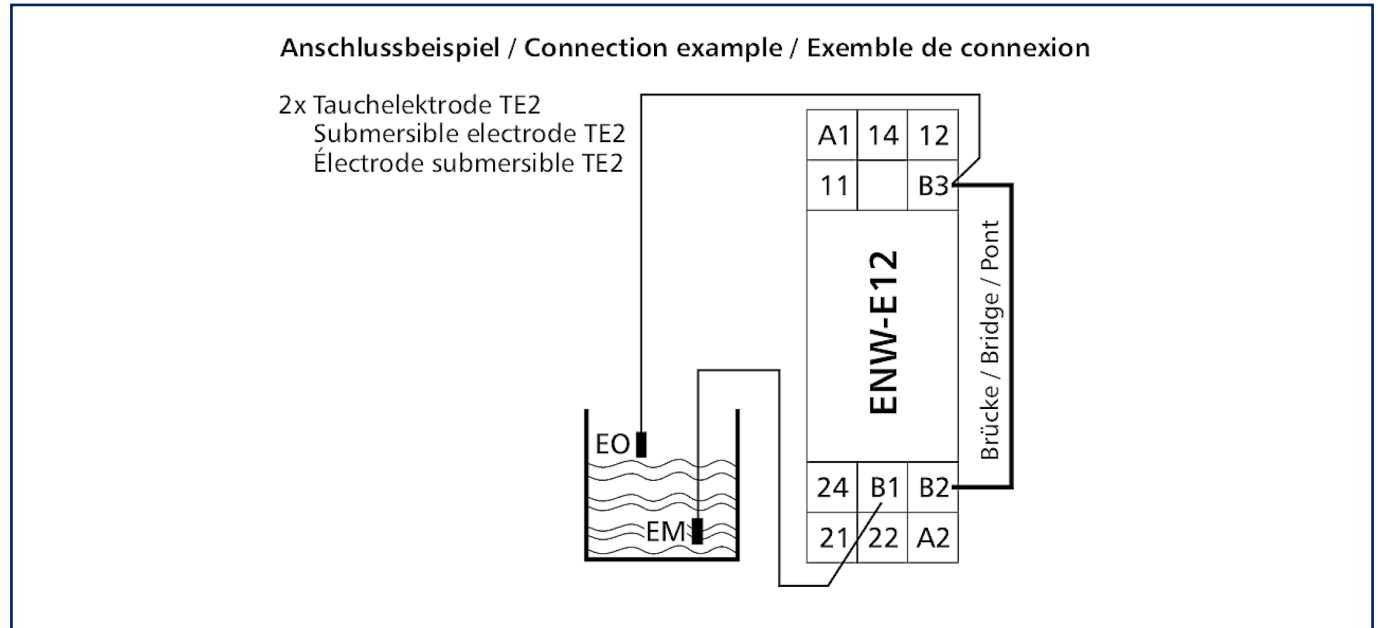

### Connection example

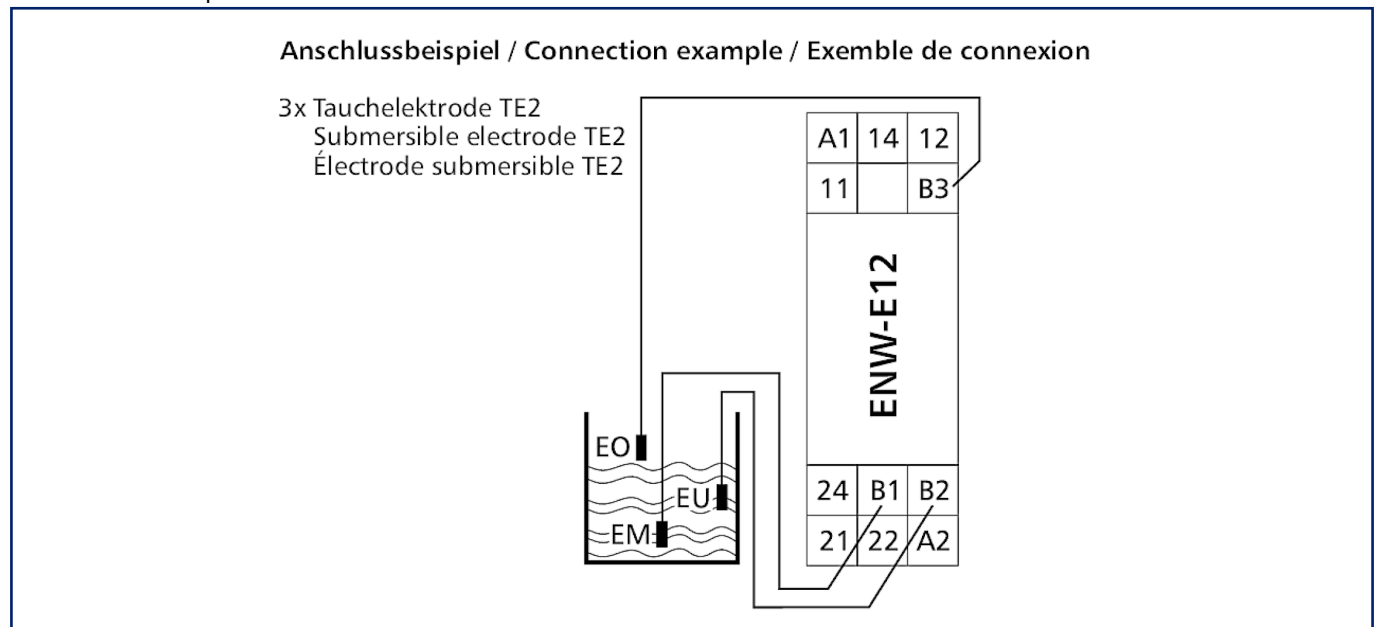

## Illustrations

Function diagram

