

# Data sheet

## MR-LD6 Modbus RTU

### Illustrations



Principle diagram

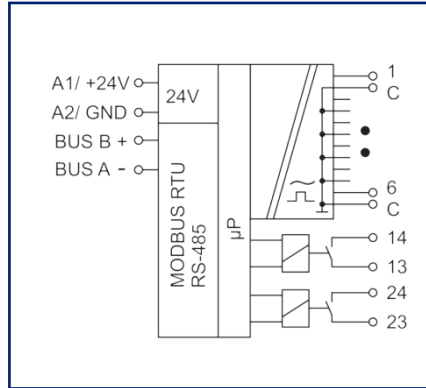

Wiring diagram

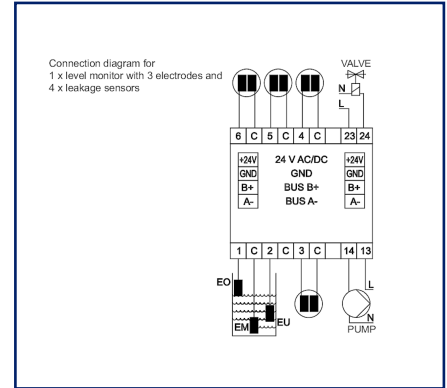

See enlarged drawings at the end of document

### Product specification

The Modbus module with 6 analog inputs and 2 relay outputs was developed for decentralized switching tasks. Suitable to monitor electrodes of leakage sensors or the fill level of fluid containers and to switch pumps or magnetic valves. In this case it is necessary to protect the relay contacts by appropriate load-dependent measures. The resistance of the conductive fluid is measured when the electrodes are immersed. It is also possible to signal a cable break (requires sensor LKS-ZD). The module can be operated independently or via a Modbus master. Inputs and outputs can be switched and scanned via standard registers. Module address, bit rate and parity are set with two rotary switches on the front or by software. Suitable for decentralized mounting on DIN TH35 rail according to IEC 60715 in electrical distribution cabinets.

- Connection with screw type terminal blocks

## Technical Data

RS485 interface	
Protocol	Modbus RTU
Address range	00 - F9
Bus interface	RS485 two wire bus with potential equalization in bus or line topology, terminate with 120 Ohm
Transmission parameters	
Transmission rate	min. 1200 Bit/s (Bd) - max. 115200 Bit/s (Bd)
Transmission rate default setting	19200 Bit/s (Bd)
Parity	None, Even (default setting), Odd
Stopbits	1 (default setting), 2
Supply	
Operating voltage	24 V AC/DC +/- 10 % (SELV)
Power consumption	
Power consumption AC (max.)	80 mA
Power consumption DC (max.)	43 mA
Duty cycle relative	100 %
Inputs	
Contacts 1 ... 6	Connecting the electrodes
Contacts C	common reference potential
Internal resistance	20 kOhm
Sine voltage	3 V <sub>eff</sub> , 70 Hz at resistance measurement
Measurement accuracy	+/- 10 % with sensor resistance 4 - 40 kOhm, +/- 20 % with sensor resistance 2 - 100 kOhm
Pulse voltage	+/- 16 V for wire break monitoring
Z-Diodes	6.2 - 10 V can be used as line termination
Cable capacity	40 nF max. corresponds to 400 m at 100 nF/km
Measuring interval	1.5 s
Outputs	
Digital outputs	2
Relay output	
Switching voltage relay output (max.)	250 V AC
Continuous current relay output	6 A / relay
Switching frequency	600 switching cycles/h
Mechanical life	5x10 <sup>6</sup> switching cycles

## Technical Data

Outputs	
Electrical life	3x10 <sup>4</sup> switching cycles
Housing	
Dimensions	
Dimension (W x H x D)	50 mm x 69.3 mm x 60 mm
Dimension (W x H x D)	1.969 in. x 2.728 in. x 2.362 in.
Total depth with switch/plug	69 mm
Weight	126 g
Mounting style	Standard rail TH35
Mounting position	any
Apposition	The maximum quantity of Modbus modules connected side-by-side is limited to 15 or to a maximum power consumption of 2 Amps (AC or DC) per connection to the power supply. For any similar block of additional modules a separate connection to the power supply is necessary., without distance
Connection type	Screw type terminal blocks
Indicator	green, red and yellow LED
Terminal blocks	
Supply and bus	
Terminal block	4-pole
Solid wire (AWG)	max. 1.5 mm <sup>2</sup> / max. 16 AWG
Stranded wire (AWG)	max. 1 mm <sup>2</sup> / max. 18 AWG
Wire diameter	max. 1.4 mm - min. 0.3 mm
Module connection	
Wire cross section solid	0.34 mm <sup>2</sup> - 2.5 mm <sup>2</sup> / AWG 22-12
Wire cross section multi	0.25 mm <sup>2</sup> - 2.5 mm <sup>2</sup> / AWG 22-12
Wire cross section with wire ferrule	0.25 mm <sup>2</sup> - 2.5 mm <sup>2</sup> / AWG 22-12
Screw torque (max.)	0.5 Nm
Stripping length (min.)	8 mm
Protection circuit	Polarity reversal protection for DC operating voltage, Protection against interchanging power supply and bus

## Technical Data

Material	
Material - Housing	Polyamid 6.6 V0
Color	gray
Material - Terminal block	Polyamid 6.6 V0
Material - Covers	Polycarbonat
Protection category according to IEC 60529	
Protection category - housing (acc. to IEC 60529)	IP40
Protection category - terminal blocks (acc. to IEC 60529)	IP20
Temperature range	
Operating	
Temperature - Operating °C	-5 °C - 55 °C
Temperature - Operating °F	23 °F - 131 °F
Storage	
Temperature - Storage °C	-20 °C - 70 °C
Temperature - Storage °F	-4 °F - 158 °F
Classifications	
ETIM 7.0	EC001584
ETIM 8.0	EC001584
ETIM 9.0	EC001584
Software and additional documents	
Software and documentation	Further documentation is available for free download at <a href="http://www.metz-connect.com">www.metz-connect.com</a>

## Accessories

P/N	Designation
11032401	Submersible electrode TE2
11032902	Leakage sensor LKS-ZD black
110369	Terminal block Type 259
110486	HUB DC
110561	Power supply NG4 24 V DC
31135104	Typ 135 RIACON 135_3.5

## Accessories from

P/N	Designation
11083001	MR-GW Modbus RTU / Modbus TCP Gateway
1108300170	MR-F-GW Modbus RTU / Modbus TCP Gateway

## Illustrations

Dimensional drawing

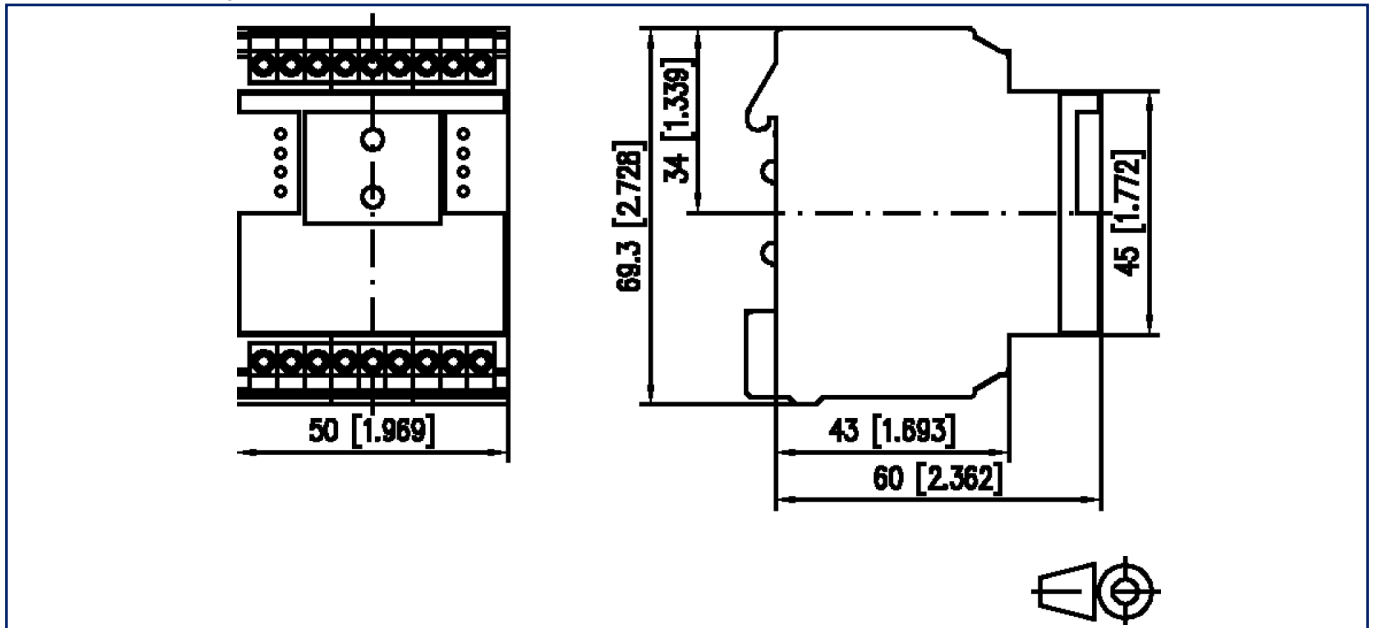

Wiring diagram

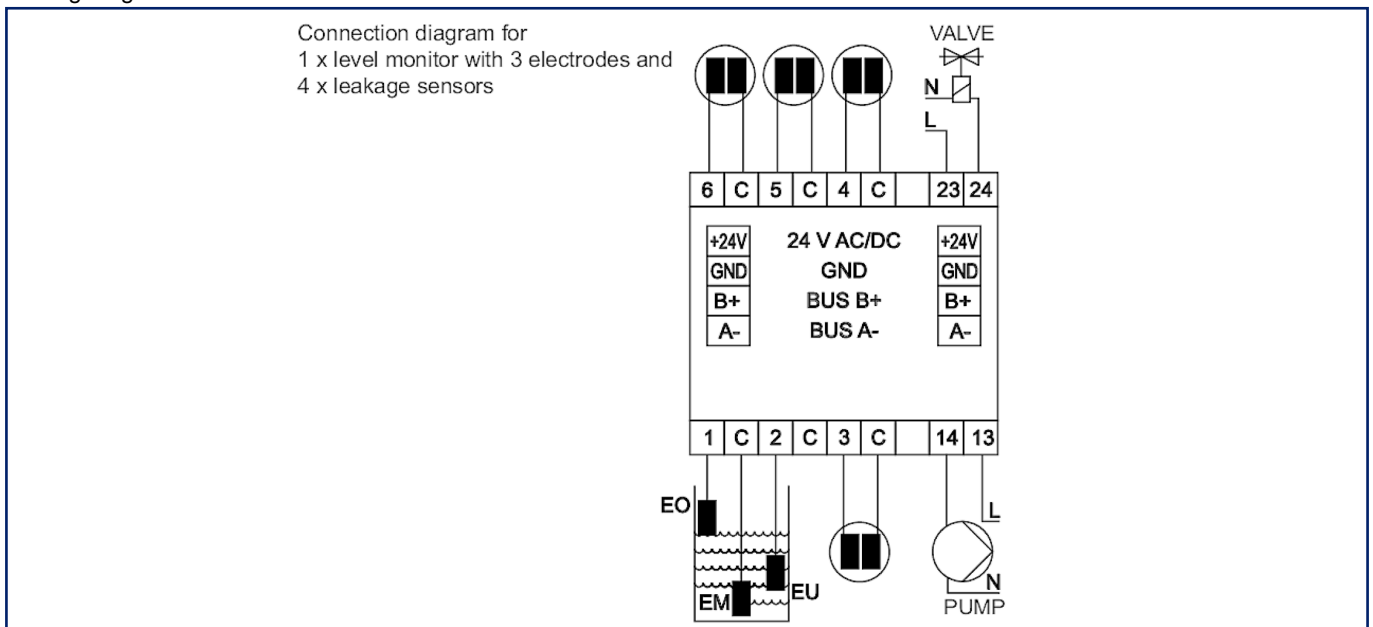

**Illustrations**

Wiring diagram

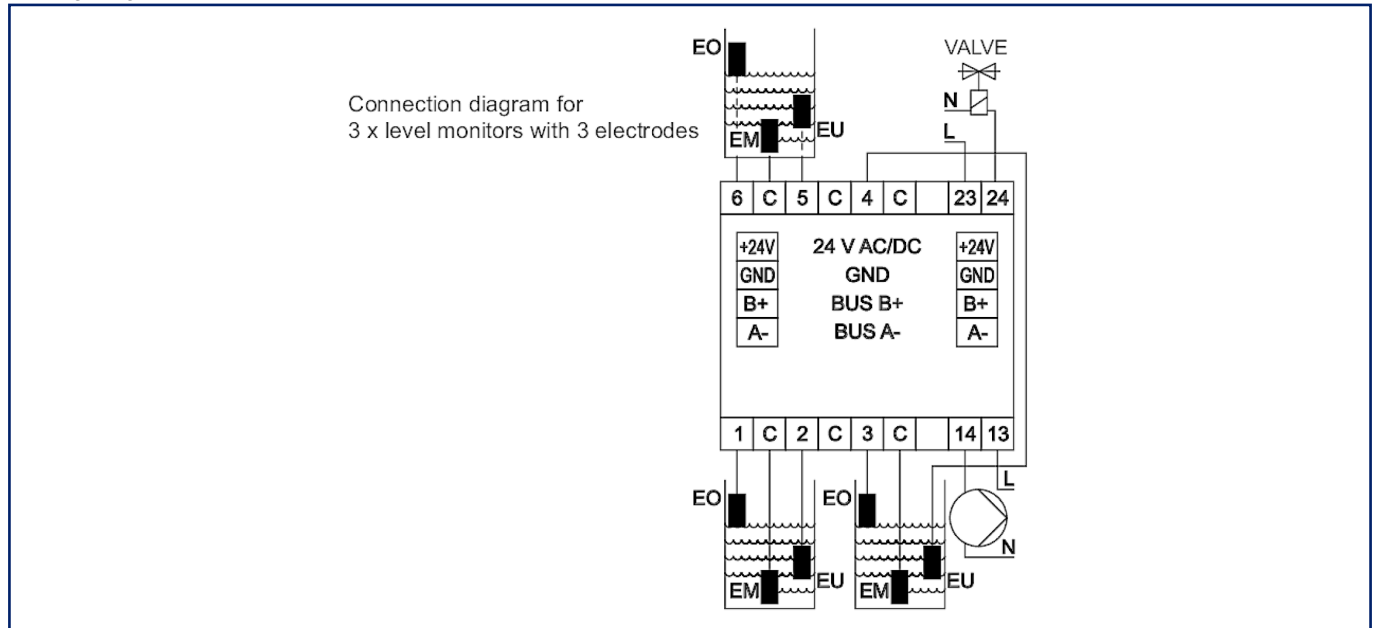

Wiring diagram

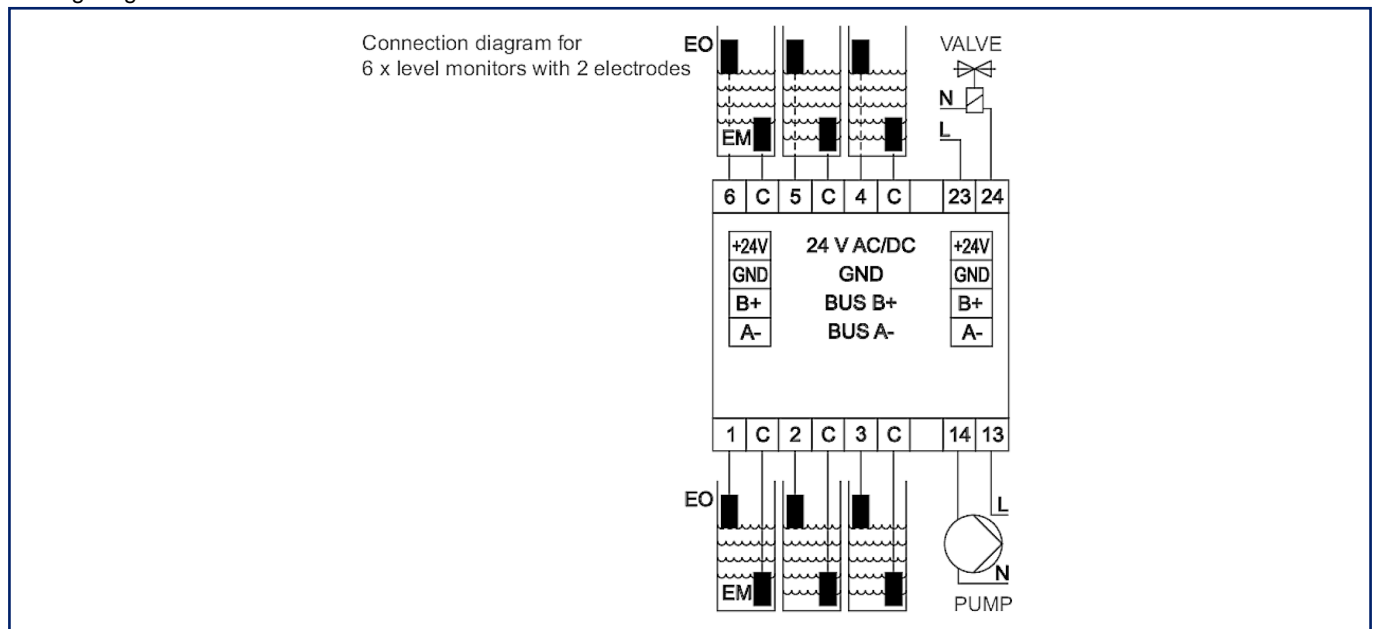

© 2023 METZ CONNECT - Technische Änderungen vorbehalten! Subject to modifications! Sous réserve de modifications techniques!



## Illustrations

Wiring diagram

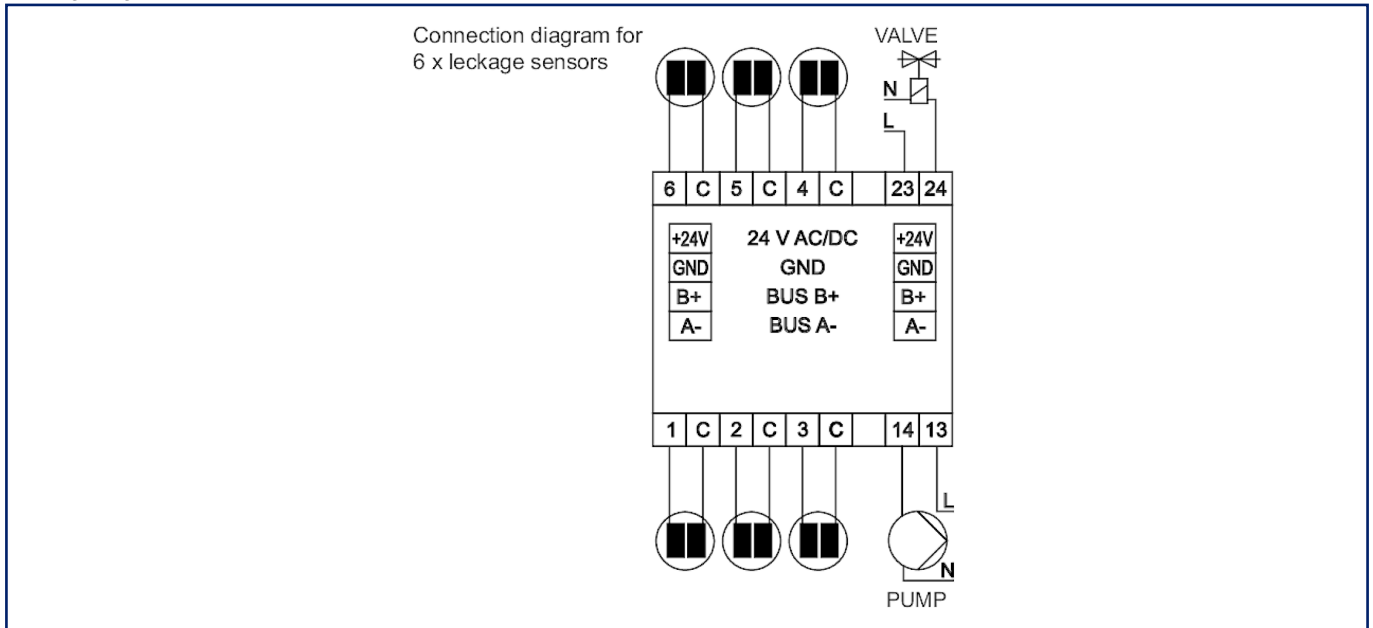

Principle diagram

