

## Illustrations

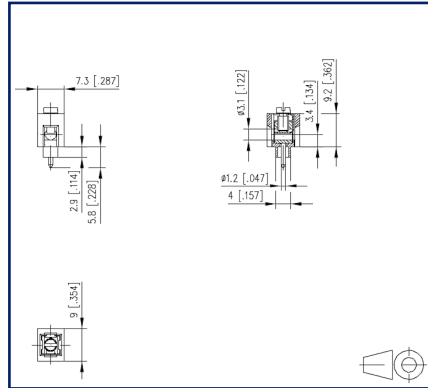

Dimensional drawing



Drill pattern

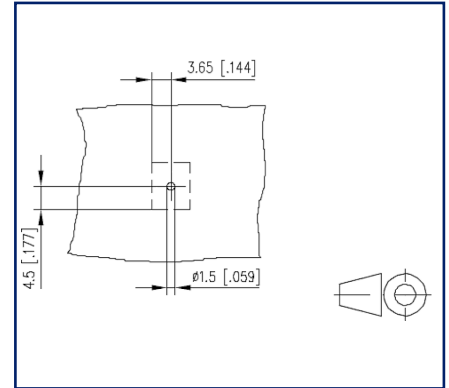

See enlarged drawings at the end of document

## Product specification

- screw type terminal block, solderable
- direction of connection 90°
- wire protector
- color black
- with molded housing, single solder pin, screw brought down by hand (transport safety)



## Technical Data

General Data	
Tightening torque SEV	0.5 Nm
Tightening torque UL	4.4 lb-in
Solder pin length	2.9 mm
min. number of poles	1
max. number of poles	1
Insulating material class	CTI 600
Terminal data	
rat.wiring solid AWGmax	0.33 mm <sup>2</sup> - 2 mm <sup>2</sup> / AWG 22 - AWG 14
rat.wiring strand.AWGmax	0.33 mm <sup>2</sup> - 1.5 mm <sup>2</sup> / AWG 22 - AWG 14
Approvals	
 V / A / AWG	50 / 15 / 24 - 14
approval UL - File No.	E121004
Material	
terminal body thread	M3
terminal body material	CuZnPb
terminal body surface	Ni + Sn
screw thread	M3
screw material	8,8
screw surface	Zn Cr(VI)-frei/free
wire protector material	CuNi18
Climatic Data	
upper limit temperature	105 °C
lower limit temperature	-40 °C
general	
Tolerance	ISO 2768 -mH
Solderability	Acc. to JEDEC JESD22-B102E 245°C/5s

**Illustrations**

Dimensional drawing

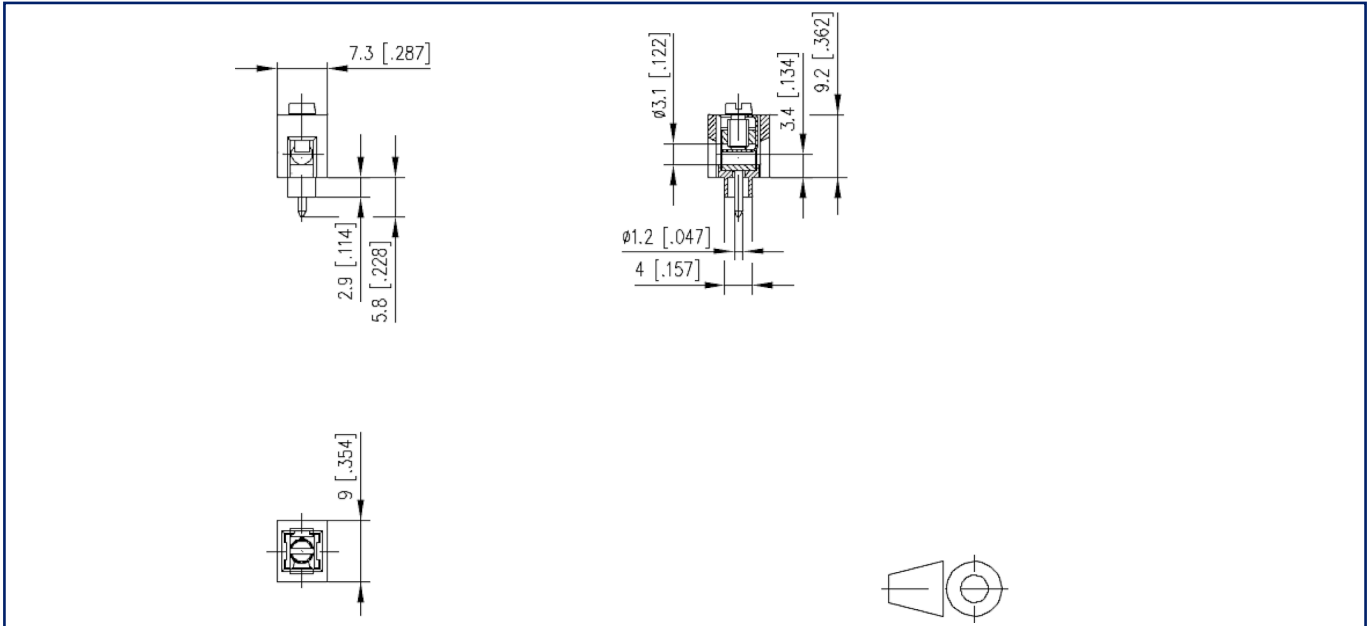

Drill pattern

