

WIRING		
DB15M	DB15F	TERMINAL BLOCK
1	1	1
2	2	2
3	3	3
4	4	4
5	5	5
6	6	6
7	7	7
8	8	8
9	9	9
10	10	10
11	11	11
12	12	12
13	13	13
14	14	14
15	15	15
SHIELD	SHIELD	SHIELD

REVISIONS			
REV.	DESCRIPTION	DATE	APPROVED
A	DRAWN IN SW	3/11/2015	BEM

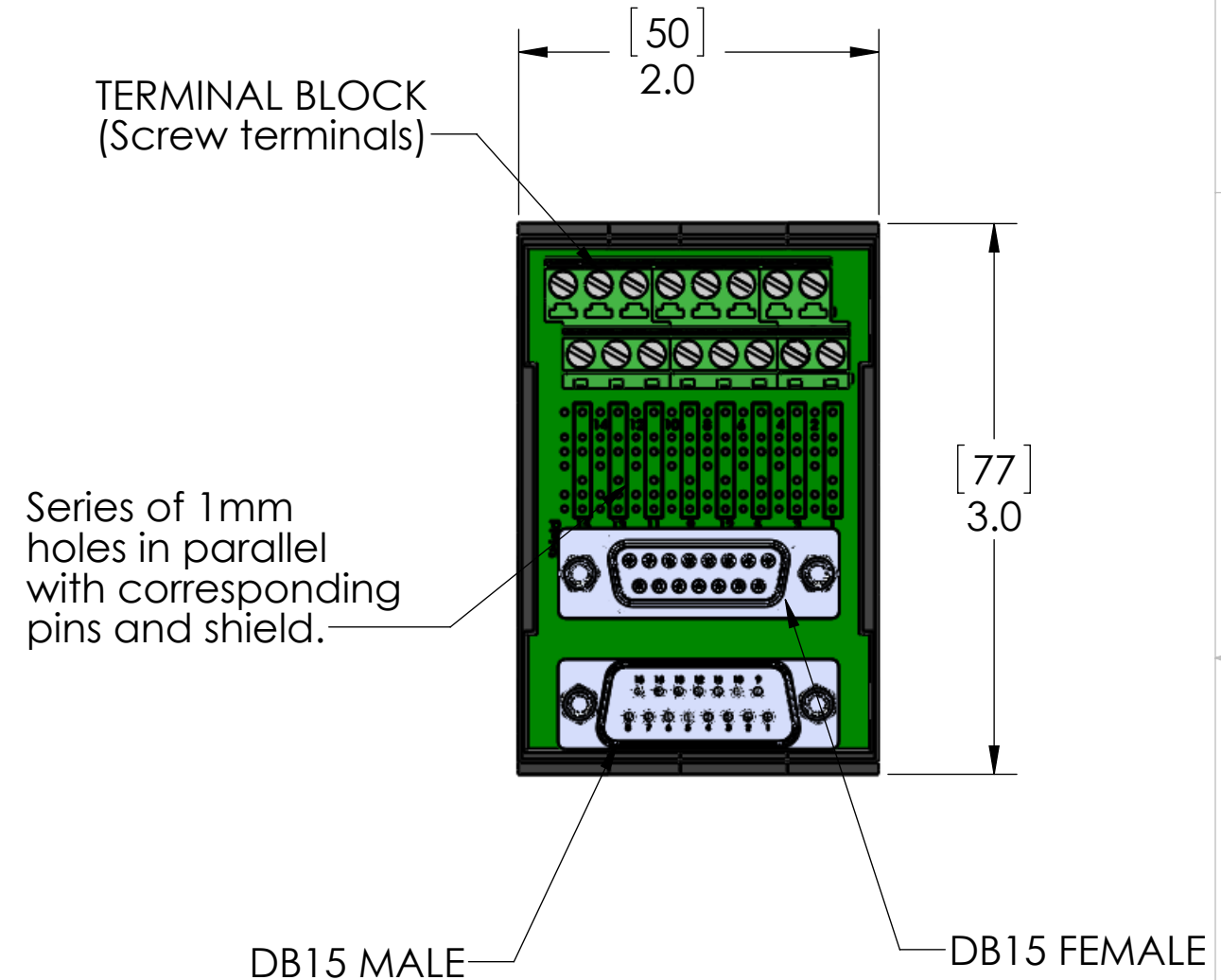
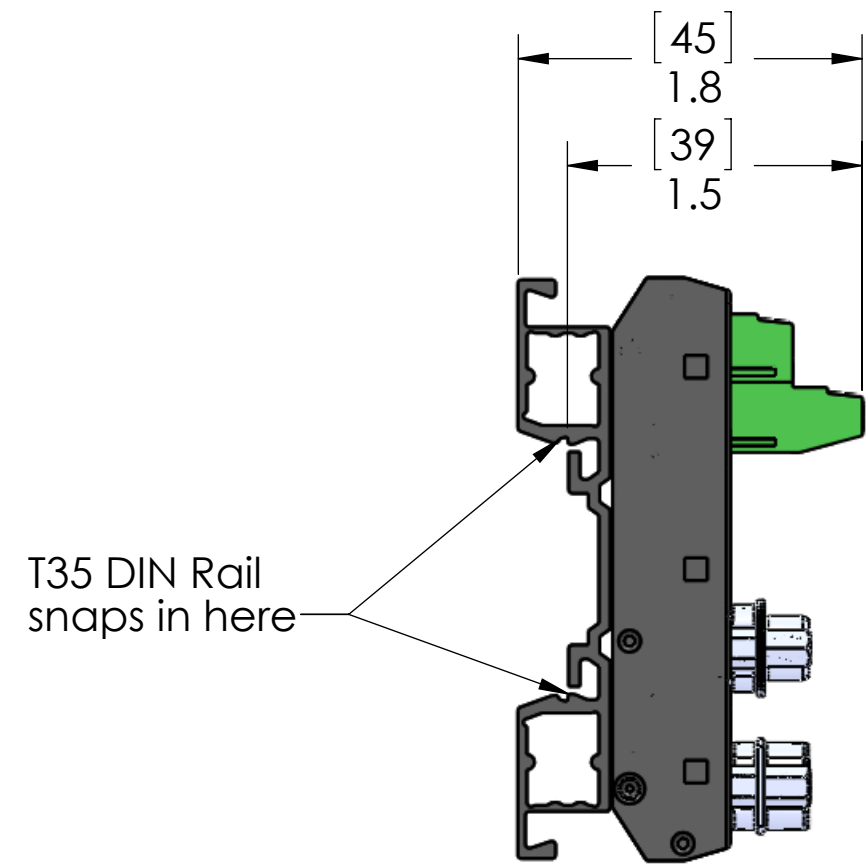

TERMINAL BLOCK SPECIFICATIONS:	
WIRE AWG:	30 - 14AWG (0.05 - 2.5sqmm)
SCREW TORQUE:	4.4 lb-in (0.5Nm)

MATERIALS:	
BODY:	BLACK PA

**PROPRIETARY AND CONFIDENTIAL**  
 THE INFORMATION CONTAINED IN THIS DRAWING IS THE SOLE PROPERTY OF MENCOM CORPORATION. ANY REPRODUCTION IN PART OR AS A WHOLE WITHOUT THE WRITTEN PERMISSION OF MENCOM CORPORATION IS PROHIBITED.

UNLESS OTHERWISE SPECIFIED: DIMENSIONS ARE IN INCHES AND [MM]	NAME	MENCOM CORPORATION	
	DRAWN	JJH	TITLE:
	CHECKED		
	ENG APPR.		
	MFG APPR.		
INTERPRET GEOMETRIC TOLERANCING PER:	Q.A.		
MATERIAL	COMMENTS:		
FINISH			
APPLICATION	DO NOT SCALE DRAWING	SIZE	DWG. NO.
		<b>B</b>	T35-DB15MF-TB
		SCALE: 1:1	REV <b>A</b>
		WEIGHT:	SHEET 1 OF 1