

| PIN # | COLOR          |
|-------|----------------|
| 1     | BLACK          |
| 2     | WHITE          |
| 3     | RED            |
| 4     | GREEN / YELLOW |

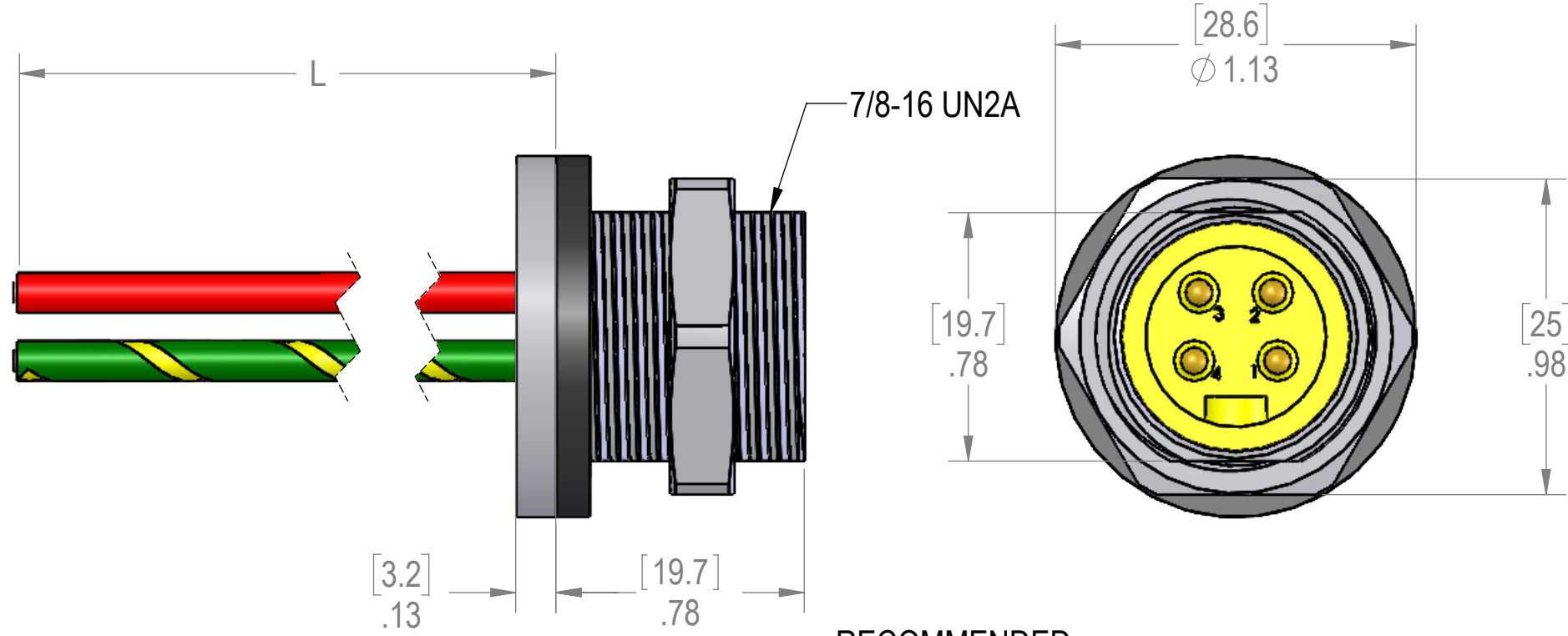

| P/N           | L           |
|---------------|-------------|
| MIN-4MR-1-BM  | 12" [0.3m]  |
| MIN-4MR-2-BM  | 24" [0.6m]  |
| MIN-4MR-3-BM  | 36" [0.9m]  |
| MIN-4MR-4-BM  | 48" [1.2m]  |
| MIN-4MR-6-BM  | 72" [1.8m]  |
| MIN-4MR-10-BM | 120" [3.1m] |
| MIN-4MR-15-BM | 180" [4.6m] |
| MIN-4MR-20-BM | 240" [6.1m] |

OTHER LENGTHS ARE AVAILABLE,  
PLEASE CONSULT FACTORY.

| MATERIALS         |                          |
|-------------------|--------------------------|
| SHELL:            | NICKEL PLATED BRASS      |
| CONTACTS:         | GOLD PLATED COPPER ALLOY |
| WIRES:            |                          |
| STYLE:            | UL 1015                  |
| AWG:              | 16 AWG                   |
| JACKET:           | PVC                      |
| VOLTAGE:          | 600V                     |
| INSERT:           | YELLOW PVC               |
| O-RING:           | NBR                      |
| NUT:              | NICKEL PLATED BRASS      |
| APPROVALS         |                          |
| US:               | UL LISTED                |
| CANADA:           | C-UL LISTED              |
| ROHS:             | YES                      |
| CE & UKCA:        | YES                      |
| RATINGS           |                          |
| PROTECTION CLASS: | UL TYPE 4 & 12, IEC IP69 |

**PROPRIETARY AND CONFIDENTIAL**  
THE INFORMATION CONTAINED IN THIS DRAWING IS THE SOLE PROPERTY OF MENCOM CORPORATION. ANY REPRODUCTION IN PART OR AS A WHOLE WITHOUT THE WRITTEN PERMISSION OF MENCOM CORPORATION IS PROHIBITED.

|       |       |
|-------|-------|
| VOLTS | 600V  |
| AMPS  | 10A   |
| TEMP: | 105°C |

| UNLESS OTHERWISE SPECIFIED:       | DRAWN BY   | ADM        |
|-----------------------------------|------------|------------|
| DIMENSIONS ARE IN INCHES AND [MM] | DRAWN DATE | 11/13/2023 |
|                                   | CHECKED BY | JJH        |
|                                   | CHECK DATE | 11/13/2023 |
|                                   | COMMENTS:  |            |
| MATERIAL                          |            |            |
| FINISH                            |            |            |
| DO NOT SCALE DRAWING              |            |            |

| MENCOM CORPORATION |               |              |
|--------------------|---------------|--------------|
| TITLE:             |               |              |
| SIZE               | DWG. NO.      | REV          |
| <b>B</b>           | MIN-4MR-ZZ-BM | <b>B</b>     |
| SCALE: 2:1         | WEIGHT:       | SHEET 1 OF 1 |