

PIN #	COLOR
1	WHITE w/ORANGE
2	WHITE w/GREEN
3	ORANGE
4	GREEN

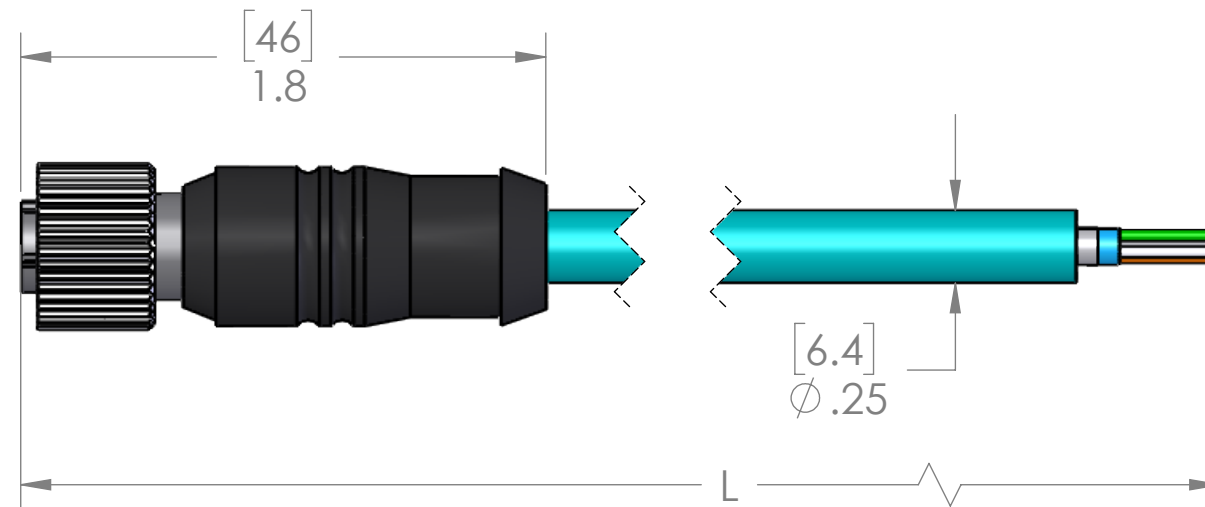
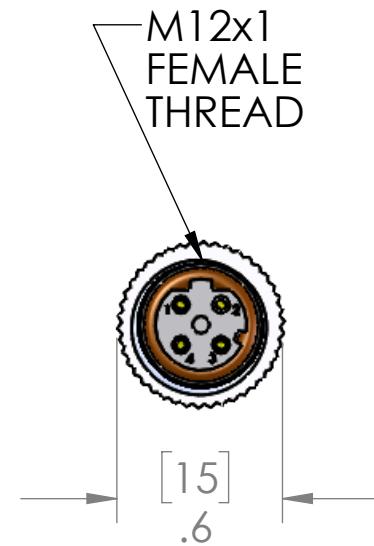

TABLE A		
P/N	L	STD?
MDE45PB-4FP-0.5M	20" [0.5m]	NO
MDE45PB-4FP-1M	40" [1m]	YES
MDE45PB-4FP-1.5M	59" [1.5m]	NO
MDE45PB-4FP-2M	79" [2m]	YES
MDE45PB-4FP-3M	118" [3m]	NO
MDE45PB-4FP-4M	157" [4m]	NO
MDE45PB-4FP-5M	197" [5m]	YES
MDE45PB-4FP-6M	236" [6m]	NO
MDE45PB-4FP-8M	315" [8m]	NO
MDE45PB-4FP-10M	393" [10m]	YES
MDE45PB-4FP-15M	590" [15m]	YES
MDE45PB-4FP-20M	786" [20m]	NO
MDE45PB-4FP-25M	983" [25m]	NO
MDE45PB-4FP-30M	1179" [30m]	NO

PARTS LISTED AS NOT BEING STANDARD  
MAY HAVE MINIMUM ORDER QUANTITIES

B MATERIALS	
BODY:	BLACK PUR
CONTACTS:	GOLD PLATED COPPER ALLOY
CABLE:	
STYLE:	AWM CAT 5e
AWG:	24 AWG
JACKET:	TEAL PUR
VOLTAGE:	600V
SHIELD:	BRAIDED
COUPLING:	NICKEL PLATED BRASS
INSERT:	POLYAMIDE
O-RING:	FPM
A APPROVALS	
US:	UL LISTED
CANADA:	C-UL LISTED
ROHS:	YES
CE & UKCA:	YES
RATINGS	
PROTECTION CLASS:	IEC IP69

**PROPRIETARY AND CONFIDENTIAL**  
THE INFORMATION CONTAINED IN THIS DRAWING IS THE SOLE PROPERTY OF MENCOM CORPORATION. ANY REPRODUCTION IN PART OR AS A WHOLE WITHOUT THE WRITTEN PERMISSION OF MENCOM CORPORATION IS PROHIBITED.

VOLTS	300V
AMPS	4A
TEMP:	80°C

UNLESS OTHERWISE SPECIFIED:	DRAWN BY	ADM
DIMENSIONS ARE IN INCHES AND [MM]	DRAWN DATE	08/23/2023
	CHECKED BY	JJH
	CHECK DATE	08/24/2023
MATERIAL	COMMENTS:	
FINISH		
DO NOT SCALE DRAWING		

MENCOM CORPORATION		
TITLE:		
SIZE	DWG. NO.	REV
<b>B</b>	MDE45PB-4FP-ZZ	<b>B</b>
SCALE: 3:2	WEIGHT:	SHEET 1 OF 2

<b>SPECIFICATIONS:</b>	
CABLE JACKET MATERIAL:	POLYURETHANE (TYPE 350B), TEAL,
CABLE DIAMETER:	OVERALL CABLE DIAMETER .236" [6.1mm] , .246"[6.25mm] MAX.
COND. JACKET MATERIAL:	POLYOLEFIN,
COND. JACKET THICKNESS:	.010" [.254mm] NOM. WALL THICKNESS (RJ45 plug compatible)
COND. STRANDING:	24 AWG 7/34 STRANDED TINNED COPPER
PAIRING:	Grn x Wht/Grn + Org x Wht/Org
SHIELD:	AN OVERALL ALUMINIZED POLYESTER FOIL SHIELD (FOIL OUT, 100%COVERAGE) SHALL BE APPLIED OVER THE CABLE CORE AND SHALL CONTAIN A 26 AWG 7/34 STRANDED TINNED COPPER DRAIN WIRE IN CONTACT WITH THE METALIZED SURFACE. A SECOND SHIELD OF 38AWG TINNED COPPER BRAID (85% MINIMUM COVERAGE), SHALL BE APPLIED OVER THE FOIL SHIELD.
WEIGHT:	Nom: 28.6#/Mft [42.6Kg/Km]
<b>ELECTRICAL REQUIREMENTS:</b>	for 100m of cable
CAT 5e	
CAPACITANCE, MUTUAL	13.5 PF/FT. AT 1 MHZ
DIELECTRIC WITHSTANDING, MIN	1500V RMS
VOLTAGE RATING, MAX.	300V
D.C. RESISTANCE, MAX.	42.6 Ω/1000'
IMPEDANCE,	100 +/- 15 Ω 1-100 MHZ
IMPEDANCE, SMOOTHED	100 +/- 10 Ω TYPICAL 5 - 100 MHZ
SRL	23 DB 1-20 MHZ
RETURN LOSS	1 - 10 MHZ 20 + 5 LOG (F) DB MIN
	10 - 20 MHZ 25 DB MIN
	20 - 100 MHZ 25- 8.6 LOG(F/20) DB MIN
PS NEXT	1-100 MHZ 64 - 15 LOG (F/.772) MIN
NEXT	1-100 MHZ 67 - 15 LOG (F/.772) MIN
PS ELFEXT	1-100 MHZ 63 - 20 LOG(F/.772) MIN
ELFEXT	1-100 MHZ 66 - 20 LOG(F/.772) MIN
ATTENUATION	1-100 MHZ 1.5[1.967 SQRT(F) +.023(F) +.05/SQRT(F)]MAX
DELAY	1-100 MHZ 534 + 36/SQRT(F)
DELAY SKEW	1-100 MHZ <25NS
LCL	1-100 MHZ -38dB MIN
VELOCITY OF PROPAGATION	68%
<b>MECHANICAL REQUIREMENTS:</b>	
EXTRUSION STYLE:	PRESSURE EXTRUSION
CONVOLUTIONS:	NONE ALLOWED. LEVEL 2 SMOOTH

DRAWN BY	ADM	<b>MENCOM CORPORATION</b>	
DRAWN DATE	08/23/2023		
CHECKED BY	JJH		
CHECK DATE	08/24/2023		
COMMENTS:		TITLE:	
SIZE	DWG. NO.	REV	
<b>B</b>	<b>MDE45PB-4FP-ZZ</b>	<b>B</b>	
SCALE: 3:2	WEIGHT:	SHEET 2 OF 2	