

8 7 6 5 4 3 2 1

REVISIONS			
REV.	DESCRIPTION	DATE	APPROVED
A	REDRAWN IN SW	6/1/2006	

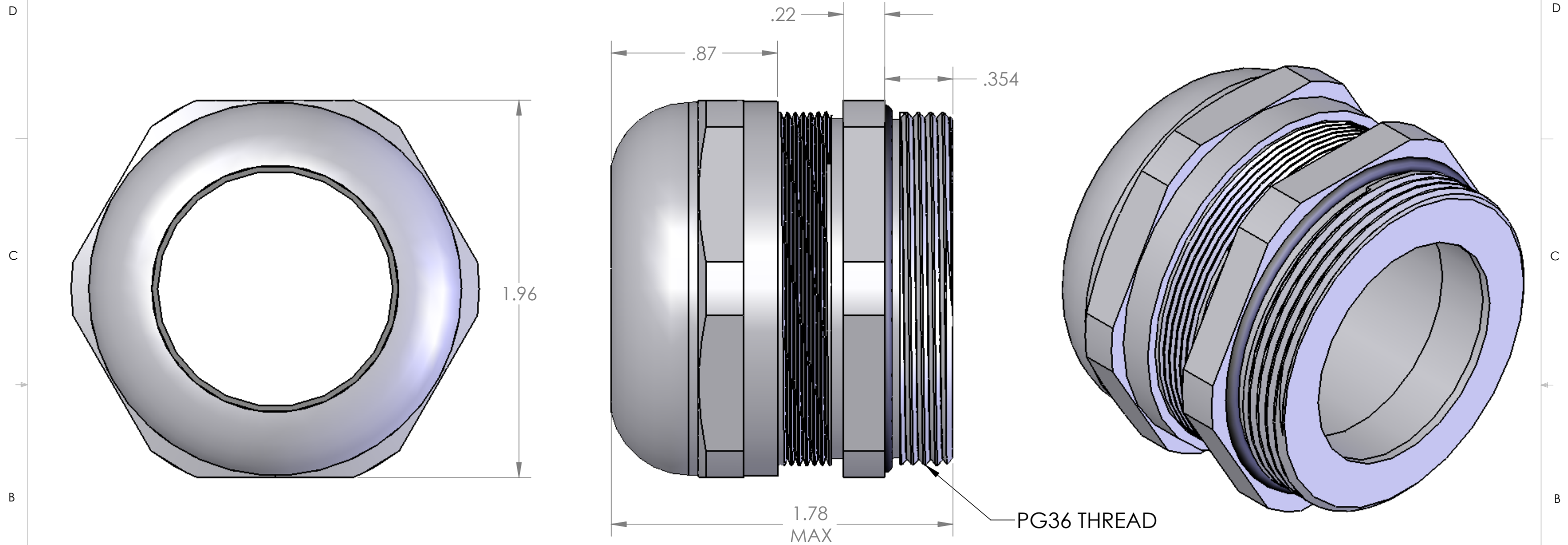

LOCK NUT INCLUDED BUT NOT SHOWN

SEAL RATED AT IP 68

SPECIFICATIONS:	
TIGHTENING TORQUE:	10 Nm
TEMPERATURE:	-20°C - +100°C

PART NUMBER	SEALING RANGE
MCG-36	.945 - 1.26 [24 - 32 mm]
MCG-36R	.787 - 1.02 [20 - 26 mm]

MATERIALS:	
BODY:	NICKEL PLATED BRASS
INSERT:	POLYAMIDE
GROMMET:	NEOPRENE
LOCK NUT:	NICKEL PLATED BRASS
O-RING:	BUNA-N

PROPRIETARY AND CONFIDENTIAL
 THE INFORMATION CONTAINED IN THIS DRAWING IS THE SOLE PROPERTY OF MENCOM CORPORATION. ANY REPRODUCTION IN PART OR AS A WHOLE WITHOUT THE WRITTEN PERMISSION OF MENCOM CORPORATION IS PROHIBITED.

UNLESS OTHERWISE SPECIFIED:		NAME
DIMENSIONS ARE IN INCHES		DWM
		DRAWN
		CHECKED
		ENG APPR.
		MFG APPR.
		Q.A.
		COMMENTS:
MATERIAL		
FINISH		
DO NOT SCALE DRAWING		

MENCOM CORPORATION		
TITLE:		
SIZE	DWG. NO.	REV
B	MCG-36	A
SCALE: 2:1	WEIGHT:	SHEET 1 OF 1

8 7 6 5 4 3 2 1