

8 7 6 5 4 3 2 1

PANEL CUTOUT

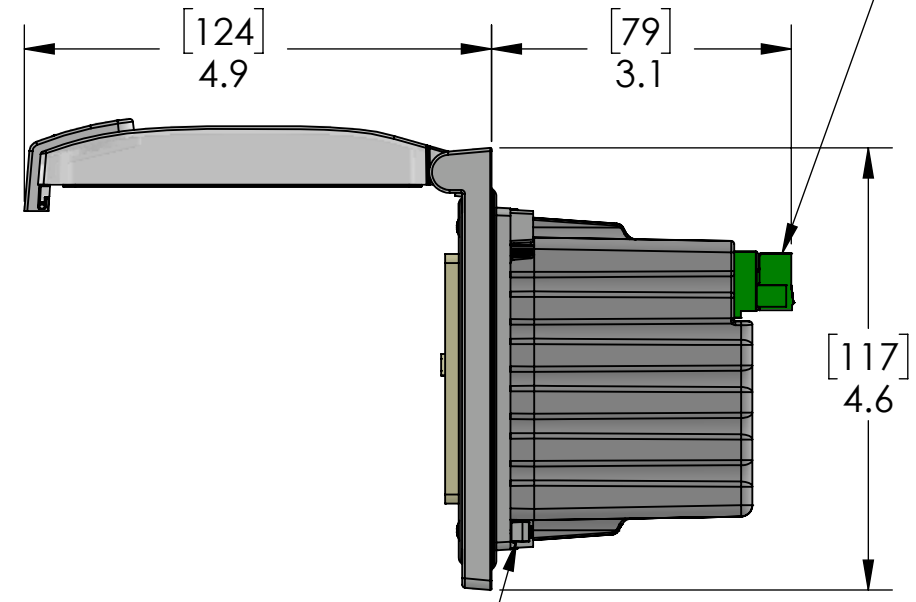

(2X) 3 POLE PLUGGABLE
TERMINAL BLOCK
FOR INCOMING POWER

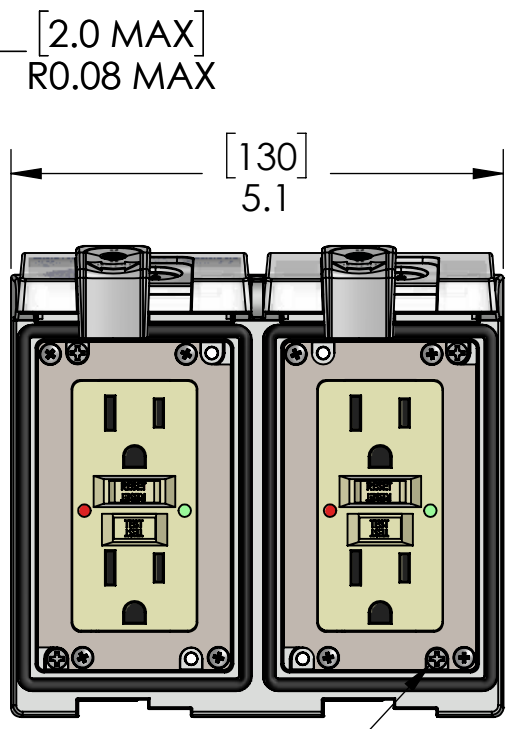
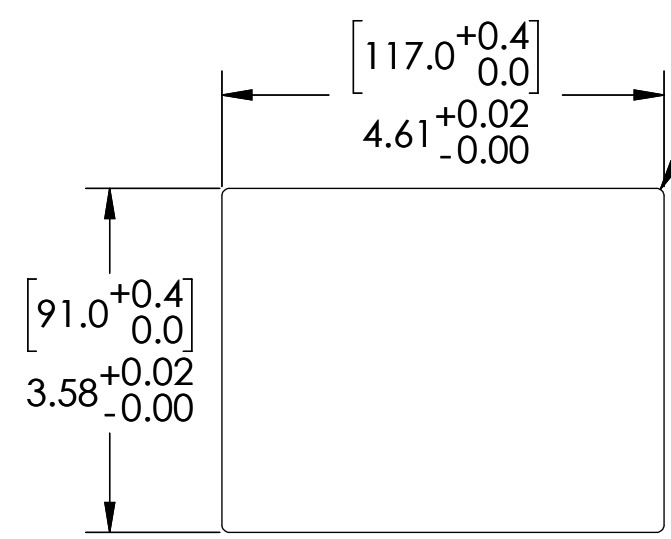
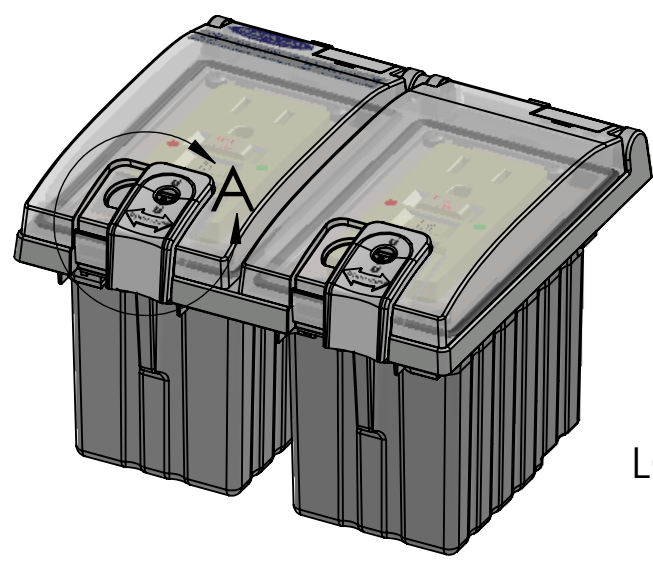
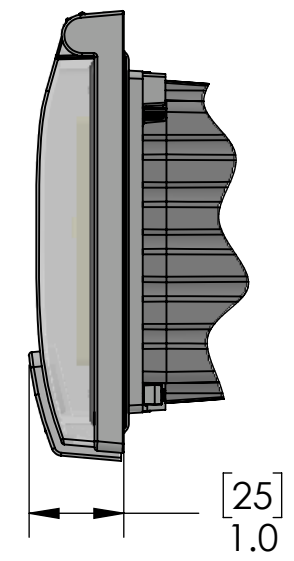

SLIDE LATCH TO OPEN/CLOSE
ROTATE LOCK TO LOCK CLOSED

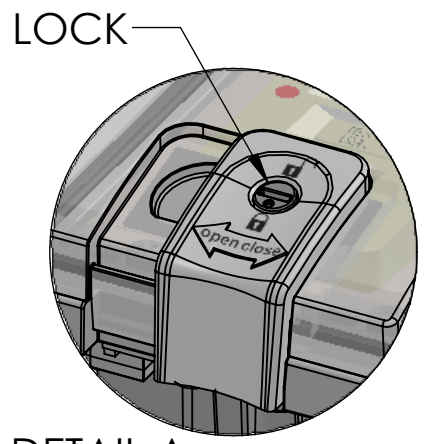

DETAIL A
SCALE 1 : 1

(X4) USE PH2 SCREW
DRIVER ON MOUNTING
SCREWS. (REF. MOUNTING
SCREW TORQUE)

ROTATE TWO TURNS COUNTER
CLOCKWISE TO RELEASE THE
TURN BUCKLE PRIOR TO TIGHTENING

TURN BUCKLES ROTATE 90 DEG. INTO
THEIR CLAMPING POSITION AS
MOUNTING SCREWS TIGHTEN.
DO NOT OVER-TORQUE!

A device employing a 15 A or 20 A grounding type receptacle but no supplementary protector shall be protected by a fuse or circuit breaker that does not exceed the marked rating of the receptacle in the end use. When a fuse or circuit breaker rated less than the receptacle's rating is provided, a Marking shall be provided to indicate the maximum ampere rating of the protection provided.

These devices shall be mounted on enclosures having adequate strength and thickness and with adequate spacing provided. Seal rating is based on mounting to a surface that is clean, flat and smooth.



PIC RATINGS/SPECIFICATIONS

VOLTS:	125V
AMPS:	15A
SCCR:	10kA
NEMA/UL EN 60529:	4, 12 IP65
PANEL THICKNESS:	5.0mm max
MOUNTING SCREW TORQUE:	0.8N-m
TERMINAL BLOCK TORQUE:	0.5N-m
INCOMING POWER WIRE SIZE:	0.25 - 2.5 sq mm / 24-12AWG
WIRE STRIP LENGTH:	7 - 8 mm

OPERATING TEMPERATURE: (-35°C / +66° C (-30° F / +150° F))

HOUSING MATERIALS		UNLESS OTHERWISE SPECIFIED:
BODY:	NICKEL PLATED ZINC	DIMENSIONS ARE IN INCHES AND [MM]
GASKETS:	PUR FIPG	
FRONT COVER:	POLYCARBONATE	
LATCH & LOCK:	PBT	
BACK COVER:	POLYPROPYLENE	

PROPRIETARY AND CONFIDENTIAL
THE INFORMATION CONTAINED IN THIS DRAWING IS THE SOLE PROPERTY OF MENCOM CORPORATION. ANY REPRODUCTION IN PART OR AS A WHOLE WITHOUT THE WRITTEN PERMISSION OF MENCOM CORPORATION IS PROHIBITED.

MATERIAL	
FINISH	
DO NOT SCALE DRAWING	

DRAWN BY:	DG
DRAWN DATE:	05/30/2019
CHECKED BY:	DCG
CHECK DATE:	05/30/2019

MENCOM CORPORATION

TITLE:
GFCI x 2; LP2

SIZE **B** DWG. NO. **LP2-2GF** REV **B**

SCALE: 1:2 WEIGHT: SHEET 1 OF 1

8 7 6 5 4 3 2 1