

PANEL CUTOUT

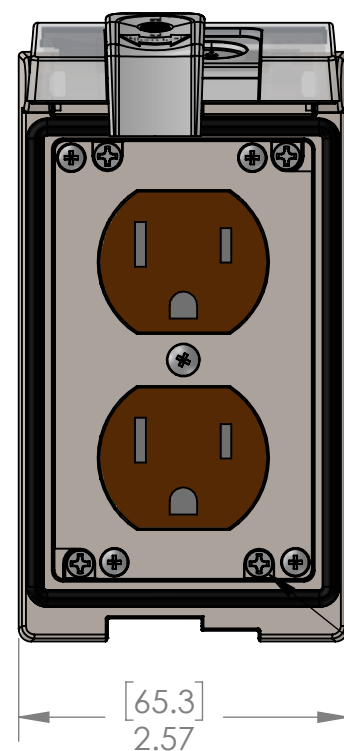
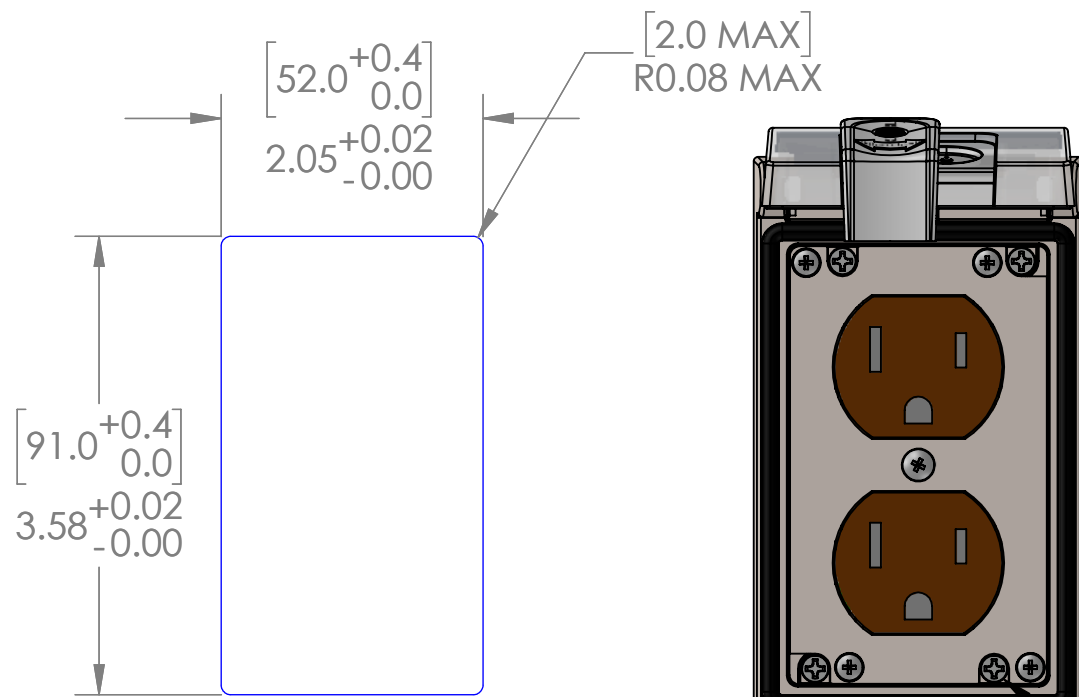

(X4) USE PH2 SCREW DRIVER ON MOUNTING SCREWS. (REF. MOUNTING SCREW TORQUE)

ROTATE TWO TURNS COUNTER CLOCKWISE TO RELEASE THE TURN BUCKLE PRIOR TO TIGHTENING

TURN BUCKLES ROTATE 90 DEG. INTO THEIR CLAMPING POSITION AS MOUNTING SCREWS TIGHTEN. DO NOT OVER-TORQUE!

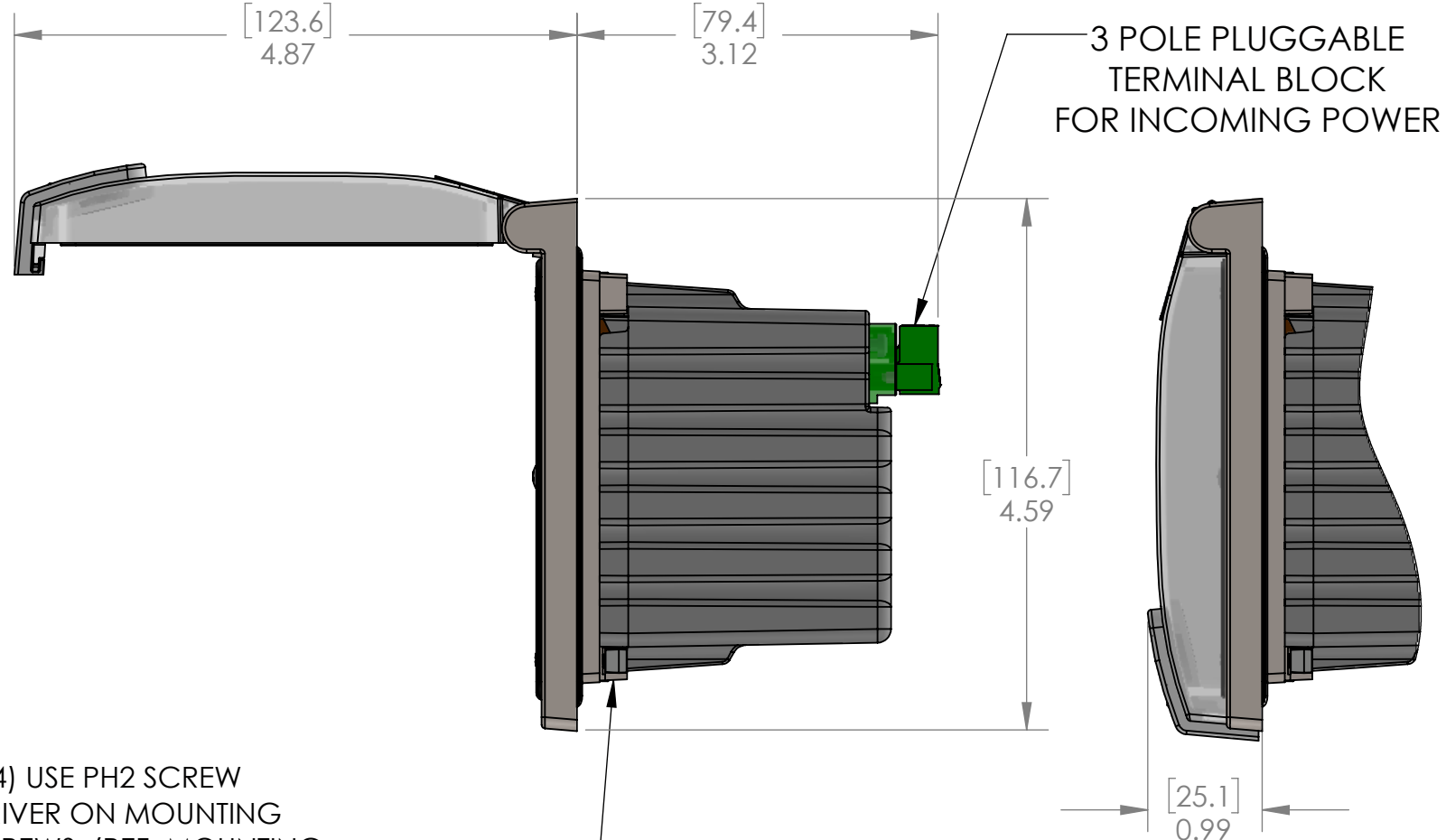

These devices shall be mounted on enclosures having adequate strength and thickness and with adequate spacing provided. Seal rating is based on mounting to a surface that is clean, flat and smooth.

PIC RATINGS/SPECIFICATIONS	
VOLTS:	125V
AMPS:	15A
SCCR:	10kA
NEMA/UL EN 60529:	4, 4X, 12 IP65
PANEL THICKNESS:	5.0mm max
MOUNTING SCREW TORQUE:	0.8N-m
TERMINAL BLOCK TORQUE:	0.5N-m
INCOMING POWER WIRE SIZE:	0.25 - 2.5 sq mm / 24-12AWG
WIRE STRIP LENGTH:	7 - 8 mm



OPERATING TEMPERATURE: (-40°C / +60° C (-40° F / +140° F))	
HOUSING MATERIALS	
BODY:	316 STAINLESS STEEL
GASKETS:	PUR FIGP
FRONT COVER:	POLYCARBONATE
LATCH & LOCK:	PBT
BACK COVER:	POLYPROPYLENE
UNLESS OTHERWISE SPECIFIED:	
DIMENSIONS ARE IN INCHES AND [MM]	
MATERIAL	
FINISH	
DO NOT SCALE DRAWING	

DRAWN BY: DCG		MENCOM CORPORATION		
DRAWN DATE: 11/06/2023				
CHECKED BY: JJH				
CHECK DATE: 11/09/2023		TITLE: DPLX; LP1SS		
COMMENTS:		SIZE: B	DWG. NO.: LP1SS-DP	REV: A
SCALE: 2:3	WEIGHT:	SHEET 1 OF 1		

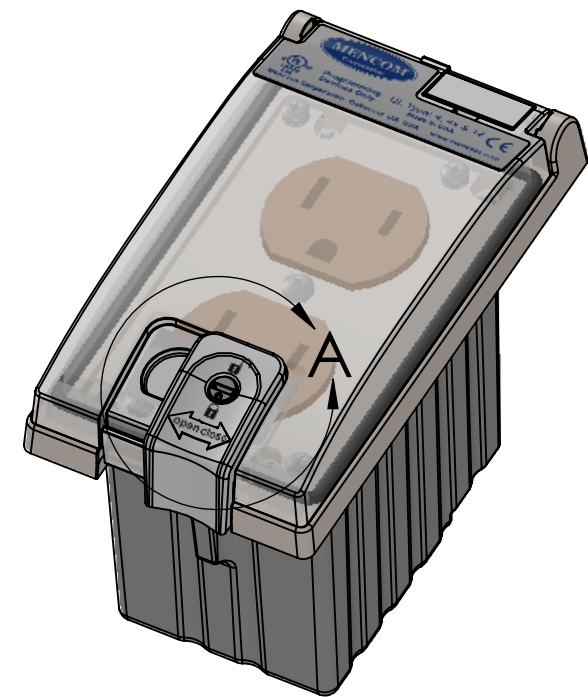

SLIDE LATCH TO OPEN/CLOSE
ROTATE LOCK TO LOCK CLOSED

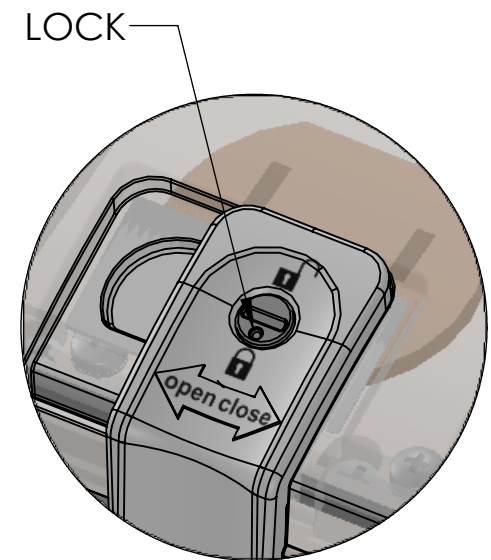

DETAIL A
SCALE 4 : 3

PROPRIETARY AND CONFIDENTIAL
THE INFORMATION CONTAINED IN THIS DRAWING IS THE SOLE PROPERTY OF MENCOM CORPORATION. ANY REPRODUCTION IN PART OR AS A WHOLE WITHOUT THE WRITTEN PERMISSION OF MENCOM CORPORATION IS PROHIBITED.