

PANEL CUTOUT

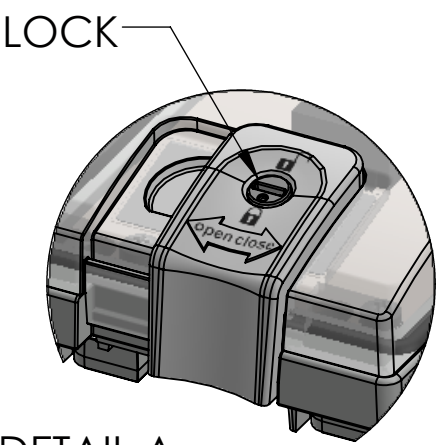
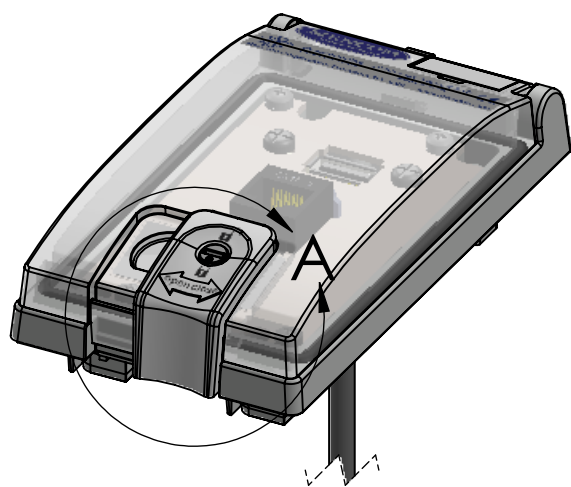
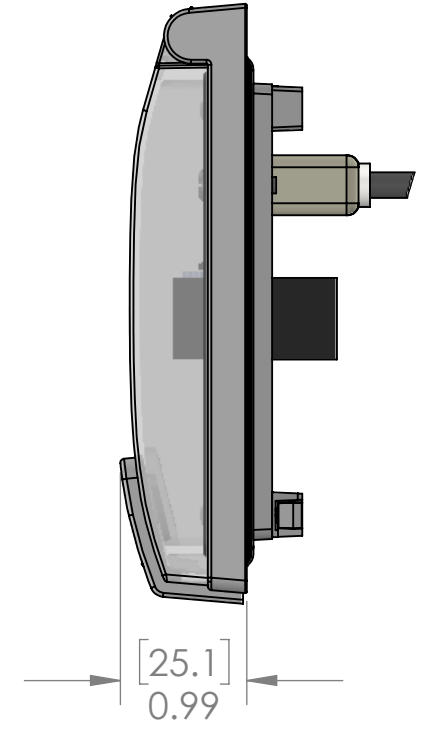
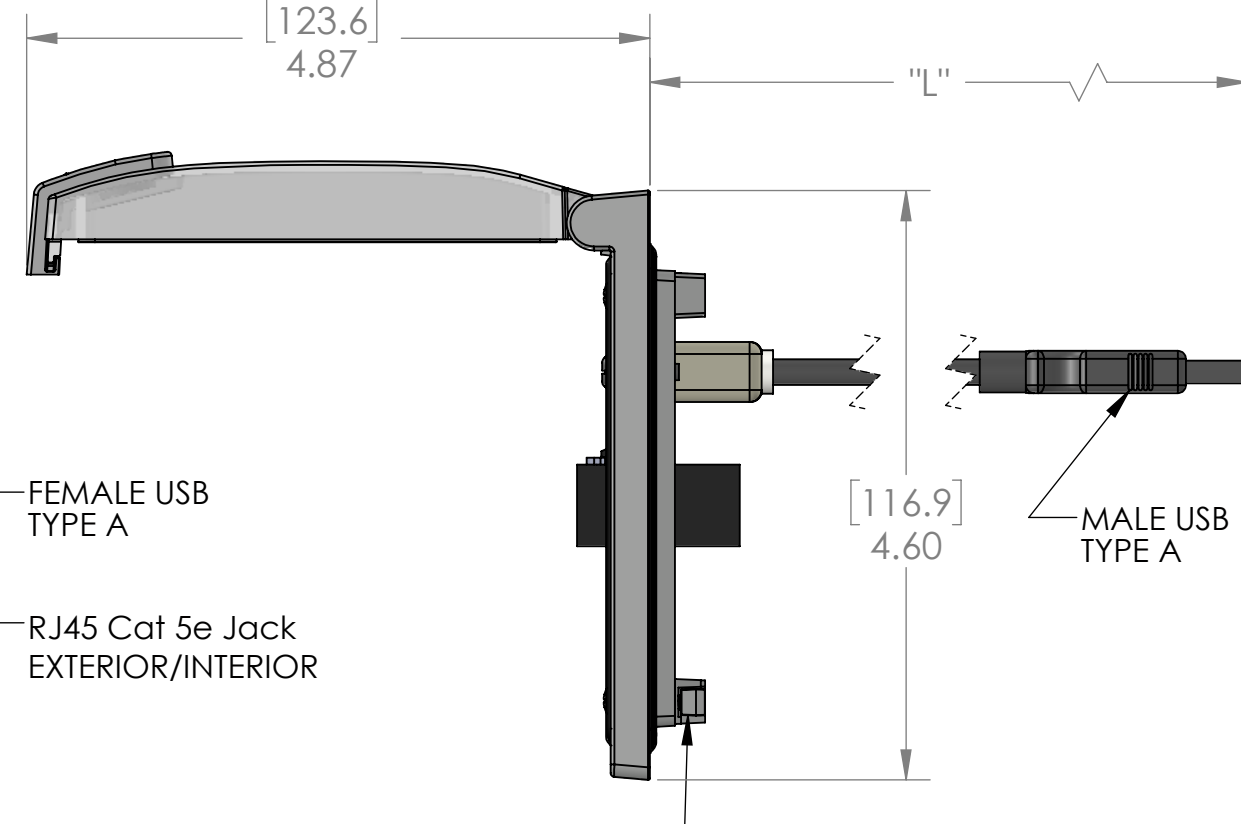
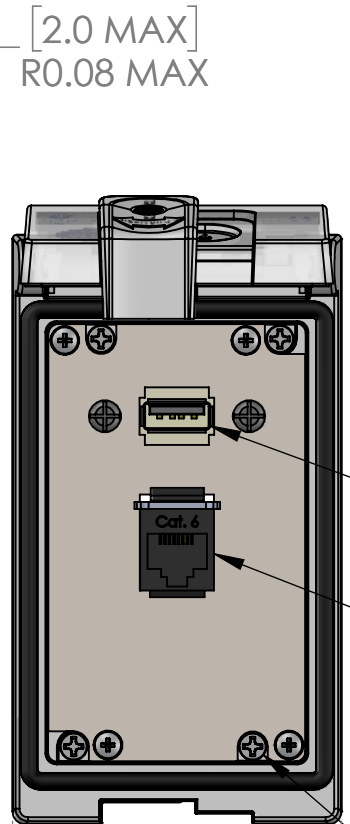
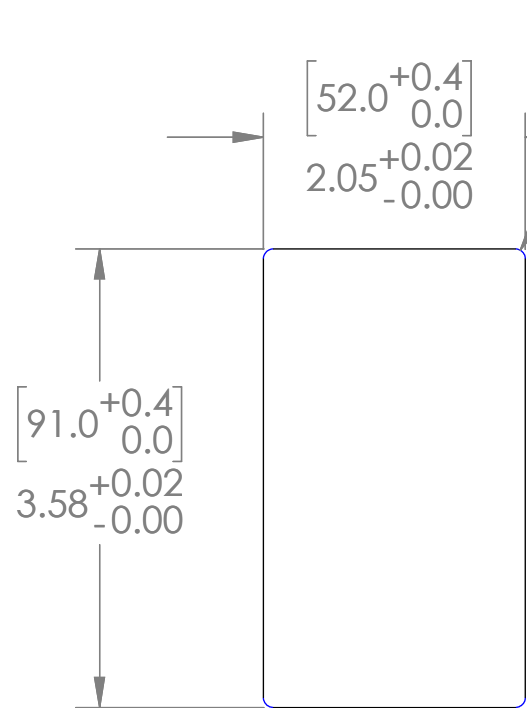

DETAIL A
SCALE 1 : 1

FEMALE USB
TYPE A

RJ45 Cat 5e Jack
EXTERIOR/INTERIOR

(X4) USE PH2 SCREW
DRIVER ON MOUNTING
SCREWS. (REF. MOUNTING
SCREW TORQUE)

ROTATE TWO TURNS COUNTER
CLOCKWISE TO RELEASE THE
TURN BUCKLE PRIOR TO TIGHTENING

TURN BUCKLES ROTATE 90 DEG. INTO
THEIR CLAMPING POSITION AS
MOUNTING SCREWS TIGHTEN.
DO NOT OVER-TORQUE!

SLIDE LATCH TO OPEN/CLOSE
ROTATE LOCK TO LOCK CLOSED

PART NUMBER	LENGTH "L"
LP1-RJ45-USB-03	3 FEET
LP1-RJ45-USB-06	6 FEET
LP1-RJ45-USB-10	10 FEET

These devices shall be mounted on enclosures having adequate strength and thickness and with adequate spacing provided. Seal rating is based on mounting to a surface that is clean, flat and smooth.



PIC RATINGS/SPECIFICATIONS		
NEMA/UL EN 60529:	4, 12	IP65
PANEL THICKNESS:	5.0mm max	
MOUNTING SCREW TORQUE:	0.8N-m	

OPERATING TEMPERATURE: (-10°C / +60° C (+14° F / +140° F))

HOUSING MATERIALS		UNLESS OTHERWISE SPECIFIED:
BODY:	NICKEL PLATED ZINC	DIMENSIONS ARE IN INCHES AND [MM]
GASKETS:	PUR / FIPG	
FRONT COVER:	POLYCARBONATE	
LATCH & LOCK:	PBT	

PROPRIETARY AND CONFIDENTIAL
THE INFORMATION CONTAINED IN THIS DRAWING IS THE SOLE PROPERTY OF MENCOM CORPORATION. ANY REPRODUCTION IN PART OR AS A WHOLE WITHOUT THE WRITTEN PERMISSION OF MENCOM CORPORATION IS PROHIBITED.

UNLESS OTHERWISE SPECIFIED:	
MATERIAL	
FINISH	
DO NOT SCALE DRAWING	

DRAWN BY:	DG
DRAWN DATE:	09/29/2017
CHECKED BY:	DWM
CHECK DATE:	10/09/2017

MENCOM CORPORATION

TITLE:
RJ45; USB ZZ; LP1

SIZE B	DWG. NO. LP1-RJ45-USB-ZZ	REV B
SCALE: 2:3	WEIGHT:	SHEET 1 OF 1