

8 7 6 5 4 3 2 1

PANEL CUTOUT

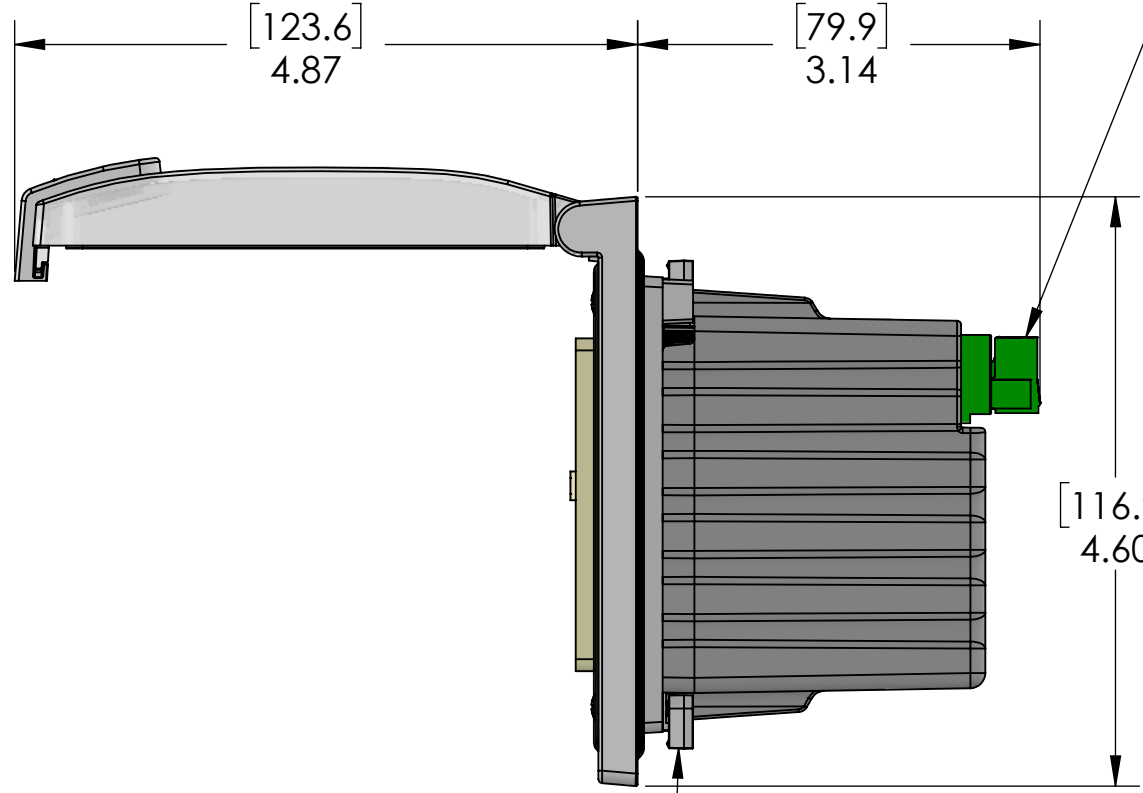

3 POLE PLUGGABLE  
TERMINAL BLOCK  
FOR INCOMING POWER

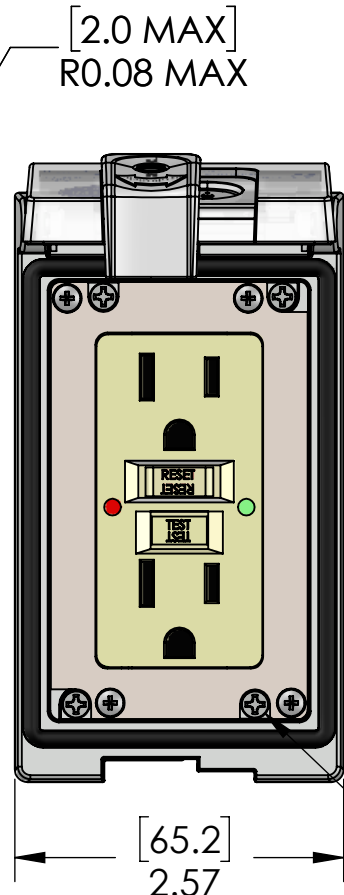
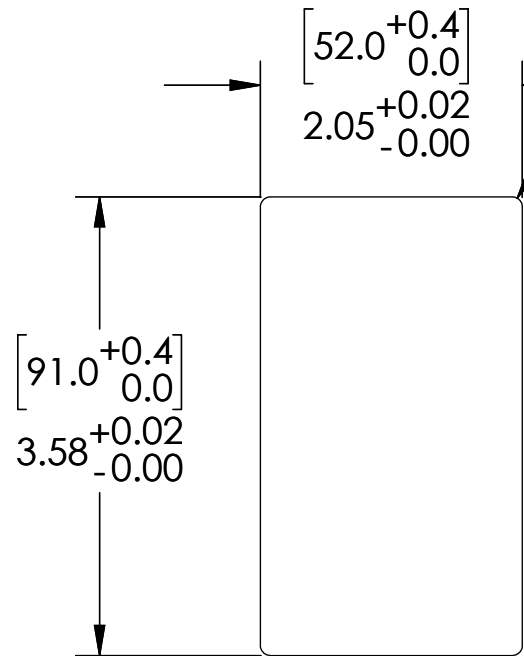
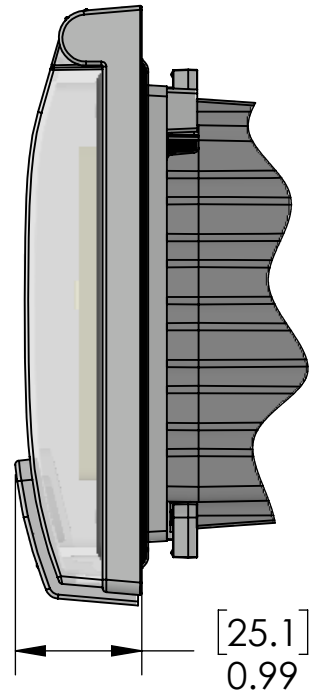

(X4) USE PH2 SCREW  
DRIVER ON MOUNTING  
SCREWS. (REF. MOUNTING  
SCREW TORQUE)

ROTATE TWO TURNS COUNTER  
CLOCKWISE TO RELEASE THE  
TURN BUCKLE PRIOR TO TIGHTENING

TURN BUCKLES ROTATE 90 DEG. INTO  
THEIR CLAMPING POSITION AS  
MOUNTING SCREWS TIGHTEN.  
DO NOT OVER-TORQUE!

A device employing a 15 A or 20 A grounding type receptacle but no supplementary protector shall be protected by a fuse or circuit breaker that does not exceed the marked rating of the receptacle in the end use. When a fuse or circuit breaker rated less than the receptacle's rating is provided, a Marking shall be provided to indicate the maximum ampere rating of the protection provided.

These devices shall be mounted on enclosures having adequate strength and thickness and with adequate spacing provided. Seal rating is based on mounting to a surface that is clean, flat and smooth.

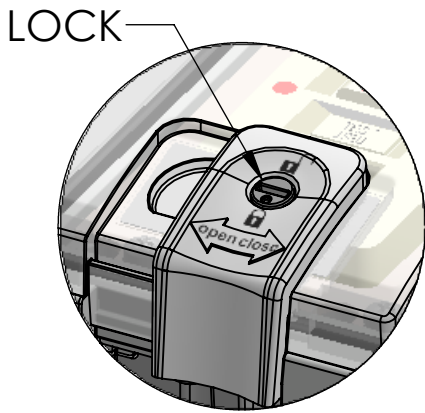
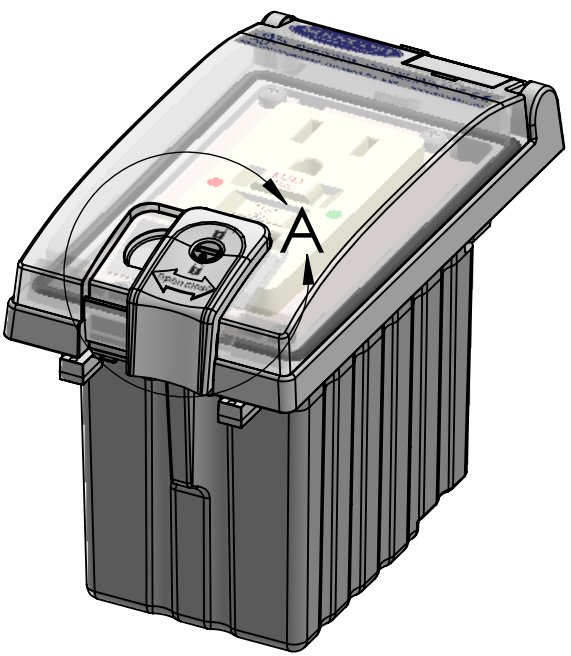

DETAIL A  
SCALE 1 : 1

SLIDE LATCH TO OPEN/CLOSE  
ROTATE LOCK TO LOCK CLOSED

PIC RATINGS/SPECIFICATIONS

VOLTS:	125V
AMPS:	15A
SCCR:	10kA
NEMA/UL   EN 60529:	4, 12   IP65
PANEL THICKNESS:	5.0mm max
MOUNTING SCREW TORQUE:	0.8N-m
TERMINAL BLOCK TORQUE:	0.5N-m
INCOMING POWER WIRE SIZE:	0.25 - 2.5 sq mm / 24-12AWG
WIRE STRIP LENGTH:	7 - 8 mm



OPERATING TEMPERATURE: (-35°C / +66° C (-30° F / +150° F))	
HOUSING MATERIALS	
BODY:	NICKEL PLATED ZINC
GASKETS:	PUR FIPG
FRONT COVER:	POLYCARBONATE
LATCH & LOCK:	PBT
BACK COVER:	POLYPROPYLENE
UNLESS OTHERWISE SPECIFIED:	
DIMENSIONS ARE IN INCHES AND [MM]	
MATERIAL	
FINISH	
DO NOT SCALE DRAWING	

DRAWN BY:	DG
DRAWN DATE:	05/30/2019
CHECKED BY:	GO
CHECK DATE:	05/30/2019

MENCOM CORPORATION

TITLE:  
**GFCI; LP1**

SIZE **B** DWG. NO. **LP1-GF** REV **C**

SCALE: 2:3 WEIGHT: SHEET 1 OF 1

**PROPRIETARY AND CONFIDENTIAL**  
THE INFORMATION CONTAINED IN THIS DRAWING IS THE SOLE PROPERTY OF MENCOM CORPORATION. ANY REPRODUCTION IN PART OR AS A WHOLE WITHOUT THE WRITTEN PERMISSION OF MENCOM CORPORATION IS PROHIBITED.

A

A

D

D

C

C

B

B