

REVISIONS			
REV.	DESCRIPTION	DATE	APPROVED
A	REDRAWN IN SW	6/23/2005	BEM
B	CHANGED TERMINAL AND WIRE CORRECTED PANEL CUTOUT DIM	10/12/2010	

D

D

C

C

B

B

A

A

PANEL CUTOUT

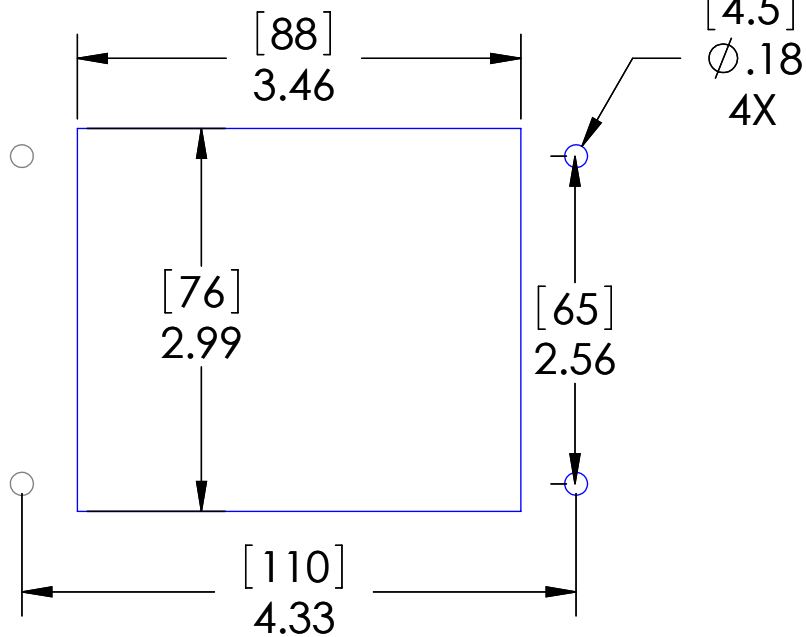

SHUKO EU1-16R
16A; 250V RECEPT

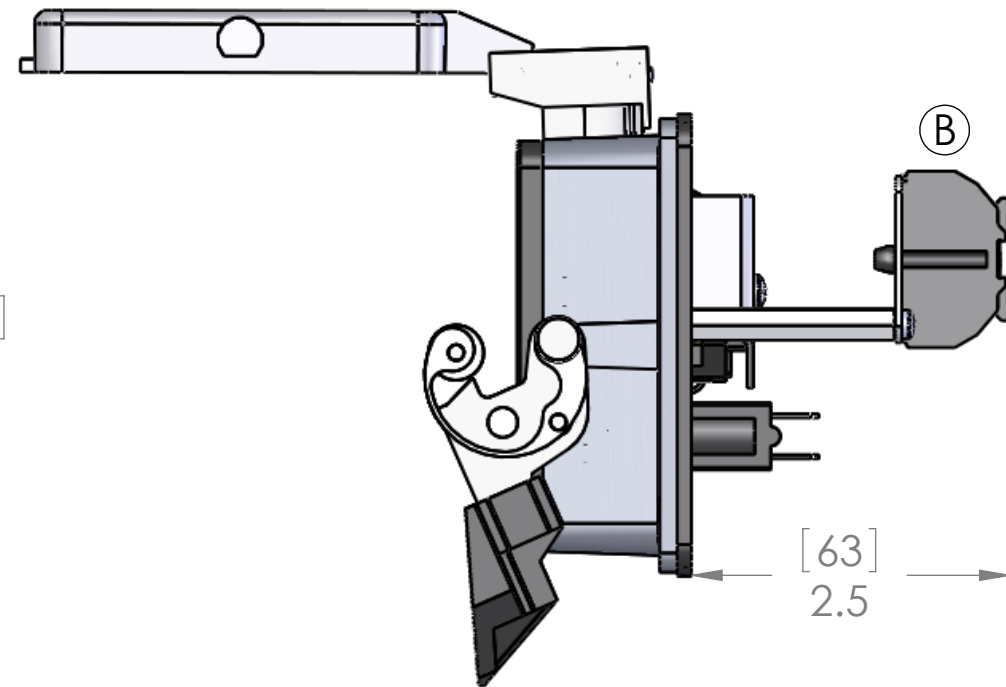
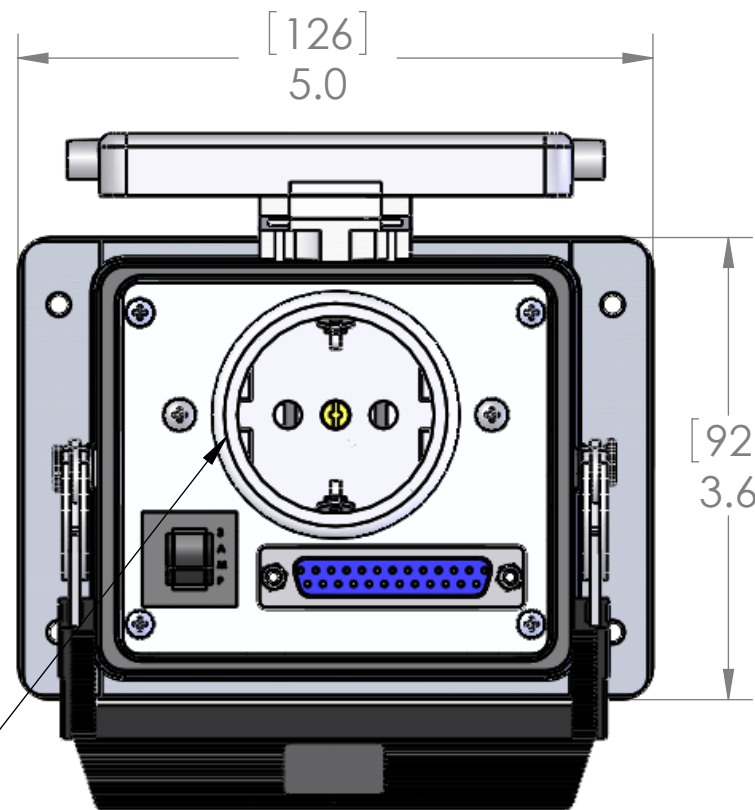

HOUSING MATERIALS	
BODY:	EPOXY COATED DIE CAST ALUMINUM
GASKET:	THERMOPLASTIC ELASTOMER
HANDLE:	POLYAMIDE
LEVERS:	STAINLESS STEEL

PIC RATINGS

VOLTS: 250V
AMPS: 3A

UNLESS OTHERWISE SPECIFIED:

DIMENSIONS ARE IN INCHES
AND [MM]

MATERIAL

FINISH

DO NOT SCALE DRAWING

DRAWN

CHECKED

ENG APPR.

MFG APPR.

Q.A.

COMMENTS:

NAME

CAM

MENCOM CORPORATION

TITLE:

SIZE

B

DWG. NO.

EP-DB25-R-32

REV

B

SCALE: 2:3

WEIGHT:

SHEET 1 OF 1

STANDARD CONFIGURATIONS UNLESS OTHERWISE NOTED

CONN. TYPE	EXTERIOR	INTERIOR
ALL D-SUBS	FEMALE	MALE

PROPRIETARY AND CONFIDENTIAL
THE INFORMATION CONTAINED IN THIS
DRAWING IS THE SOLE PROPERTY OF
MENCOM CORPORATION. ANY
REPRODUCTION IN PART OR AS A WHOLE
WITHOUT THE WRITTEN PERMISSION OF
MENCOM CORPORATION IS
PROHIBITED.