

8 7 6 5 4 3 2 1

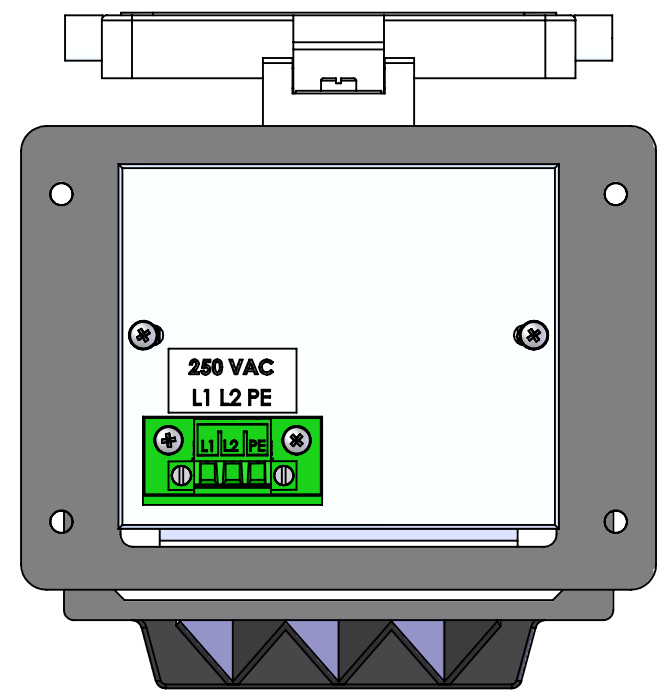

UNITED KINGDOM RECEPTACLE (BS 1363A)

PANEL CUTOUT

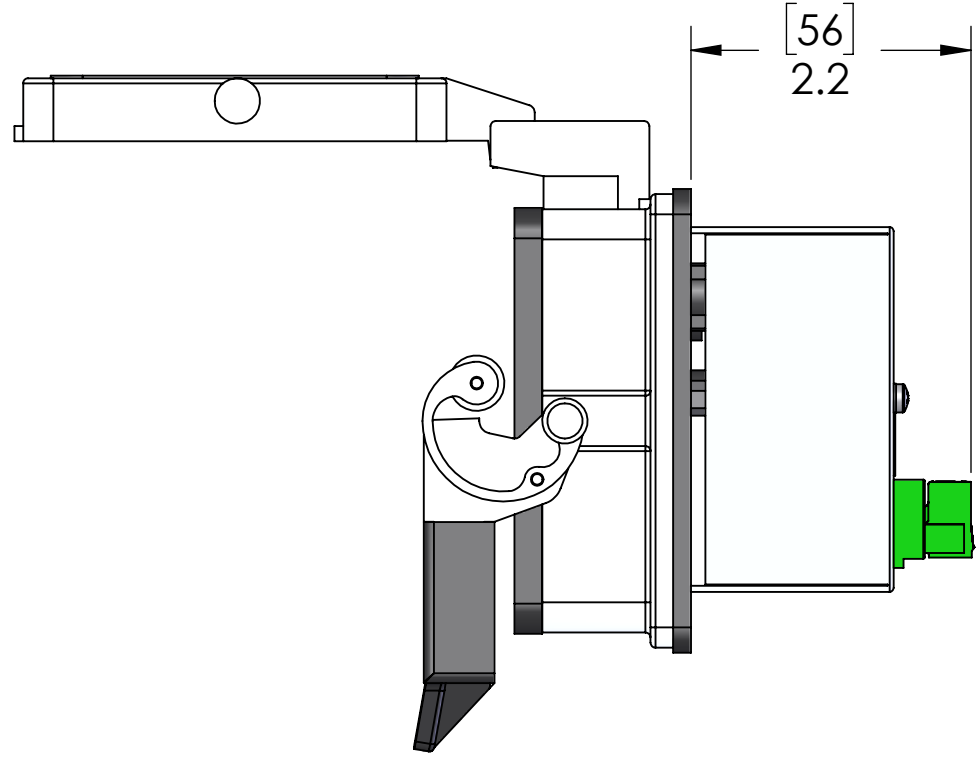
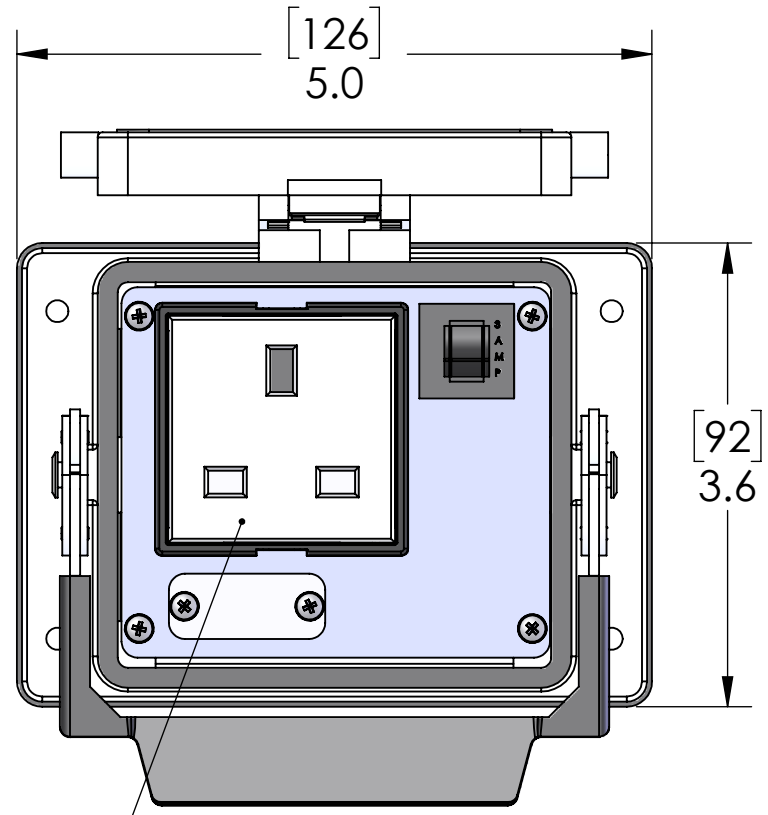
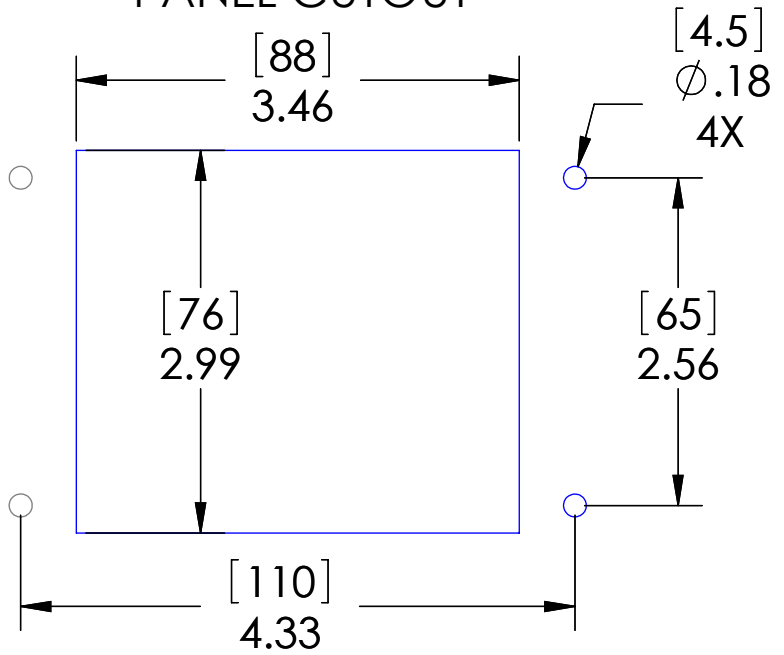

These devices shall be mounted on enclosures having adequate strength and thickness and with adequate spacing provided. Seal rating is based on mounting to a surface that is clean, flat and smooth.

HOUSING MATERIALS	
BODY:	EPOXY COATED DIE CAST ALUMINUM
GASKET:	THERMOPLASTIC ELASTOMER
HANDLE:	POLYAMIDE
LEVERS:	STAINLESS STEEL

OPERATING TEMPERATURE: (-5°C / +50° C (+23° F / +122° F))
 MOUNTING KIT ORDERED SEPARATELY CONTAINS M4x0.7 SS SCREW, NYLON WASHER, SPLIT LOCKWASHER AND M4 NUT
P/N: D-PIC-MT

PROPRIETARY AND CONFIDENTIAL
 THE INFORMATION CONTAINED IN THIS DRAWING IS THE SOLE PROPERTY OF MENCOM CORPORATION. ANY REPRODUCTION IN PART OR AS A WHOLE WITHOUT THE WRITTEN PERMISSION OF MENCOM CORPORATION IS PROHIBITED.

UNLESS OTHERWISE SPECIFIED:	
DIMENSIONS ARE IN INCHES AND [MM]	
MATERIAL	
FINISH	
DO NOT SCALE DRAWING	

PIC RATINGS/SPECIFICATIONS	
VOLTS:	250V
AMPS:	3A
SCCR:	0.2kA
NEMA/UL EN 60529:	4, 4X, 12 IP65
MOUNTING SCREW SIZE:	M4 (8-32) (304 or 316SS for 4X)
MOUNTING SCREW TORQUE:	1.2~1.8N-m (0.9~1.3 Lb-Ft)
INCOMING POWER WIRE SIZE:	0.5 ~ 4.0 sq mm / 20-12AWG
WIRE STRIP LENGTH:	10 ~ 11 mm

DRAWN BY:	ADM
DRAWN DATE:	08/09/2024
CHECKED BY:	DCG
CHECK DATE:	08/09/2024

MENCOM CORPORATION
 TITLE:
 UK RCP; 3A; 32

SIZE	DWG. NO.	REV
B	DUK-R-32	B
SCALE: 2:3	WEIGHT:	SHEET 1 OF 1