

8 7 6 5 4 3 2 1

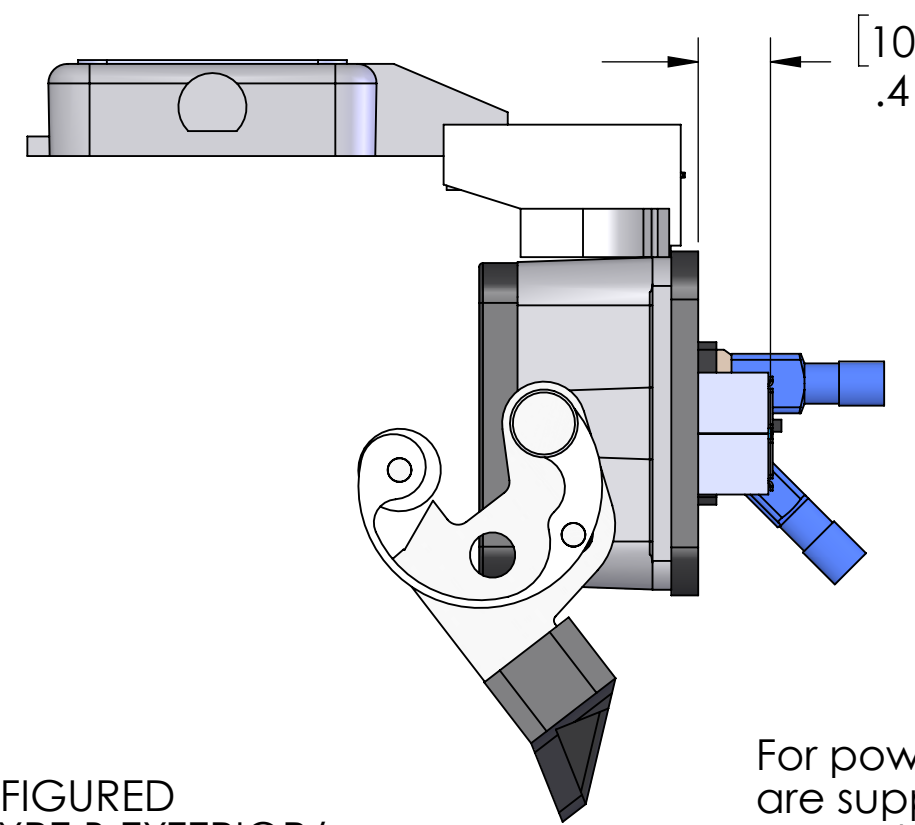
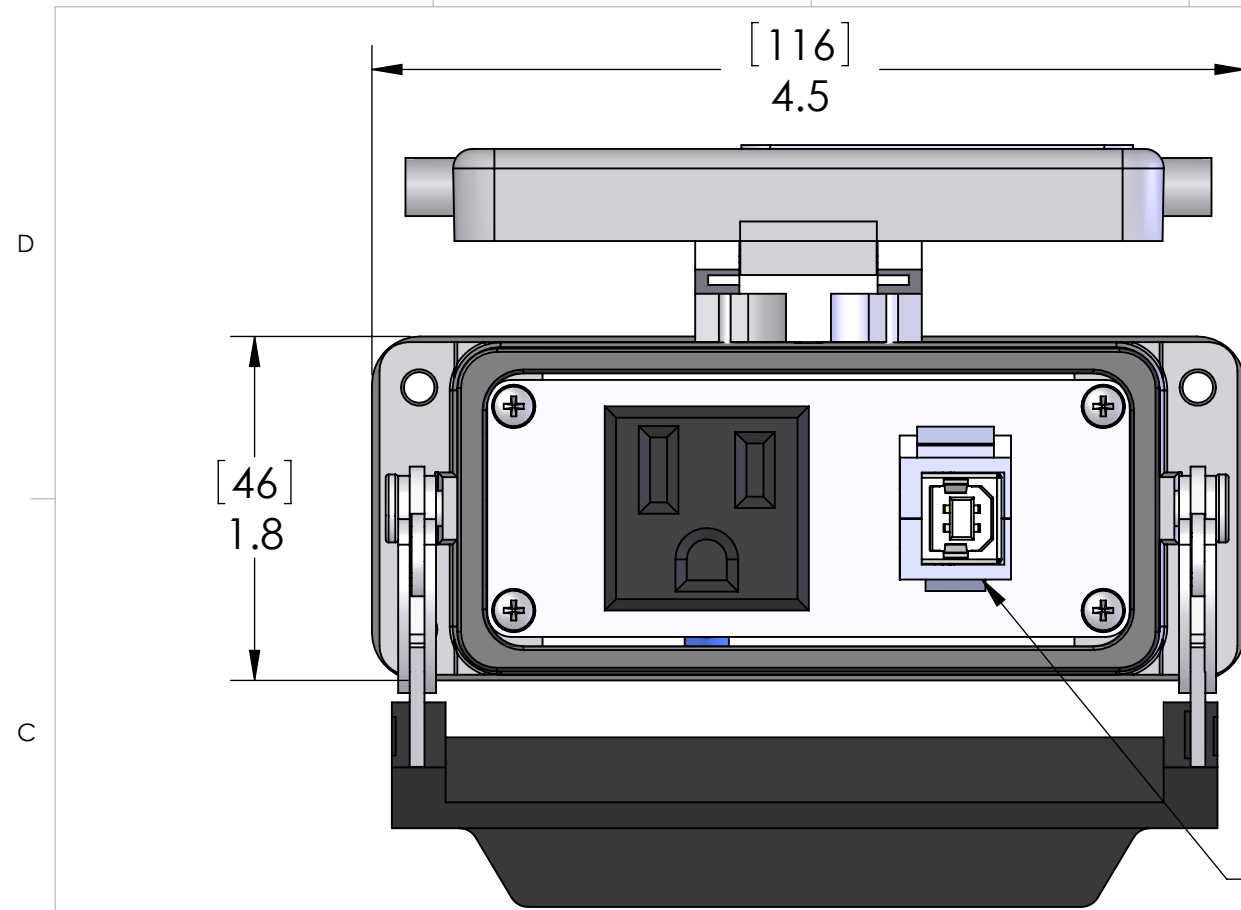

USB CONFIGURED  
FEMALE TYPE B EXTERIOR/  
FEMALE TYPE A INTERIOR

For power connector, crimp terminals are supplied for hot, neutral and ground connections.

A device employing a 15 A or 20 A grounding type receptacle but no supplementary protector shall be protected by a fuse or circuit breaker that does not exceed the marked rating of the receptacle in the end use. When a fuse or circuit breaker rated less than the receptacle's rating is provided, a Marking shall be provided to indicate the maximum ampere rating of the protection provided.

These devices shall be mounted on enclosures having adequate strength and thickness and with adequate spacing provided. Seal rating is based on mounting to a surface that is clean, flat and smooth.

PANEL CUTOUT

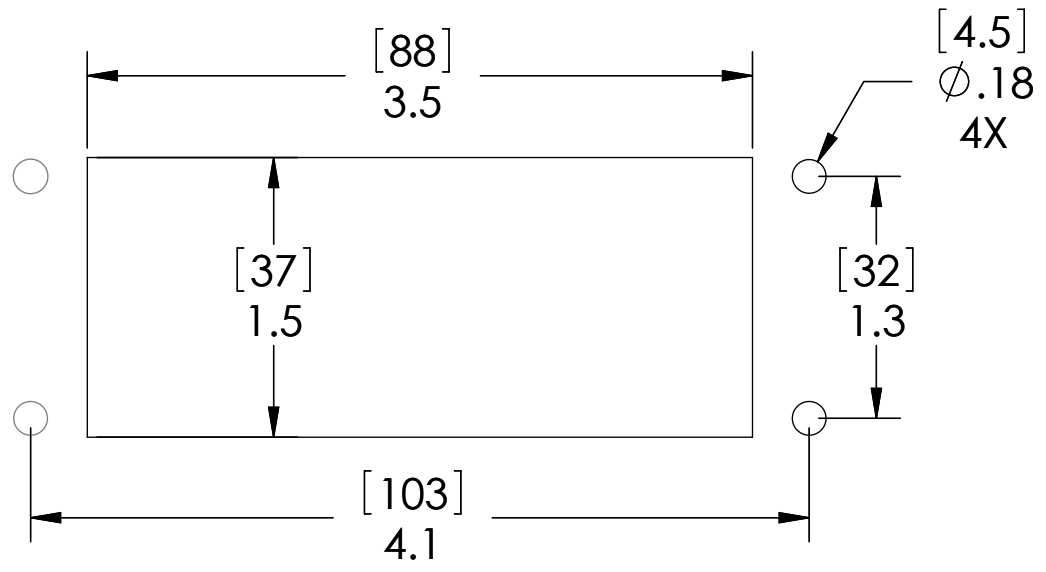

HOUSING MATERIALS	
BODY:	EPOXY COATED DIE CAST ALUMINUM
GASKET:	THERMOPLASTIC ELASTOMER
HANDLE:	POLYAMIDE
LEVERS:	STAINLESS STEEL

OPERATING TEMPERATURE: (-10°C / +75° C (+14° F / +167° F))

MOUNTING KIT ORDERED SEPARATELY CONTAINS M4x0.7 SS SCREW, NYLON WASHER, SPLIT LOCKWASHER AND M4 NUT  
P/N: D-PIC-MT



**PROPRIETARY AND CONFIDENTIAL**  
THE INFORMATION CONTAINED IN THIS DRAWING IS THE SOLE PROPERTY OF MENCOM CORPORATION. ANY REPRODUCTION IN PART OR AS A WHOLE WITHOUT THE WRITTEN PERMISSION OF MENCOM CORPORATION IS PROHIBITED.

UNLESS OTHERWISE SPECIFIED:	
DIMENSIONS ARE IN INCHES AND [MM]	
MATERIAL	
FINISH	
DO NOT SCALE DRAWING	

PIC RATINGS/SPECIFICATIONS	
VOLTS:	125V
AMPS:	15A
SCCR:	10kA
NEMA/UL   EN 60529:	4, 4X, 12   IP65
MOUNTING SCREW SIZE:	M4 (8-32) (304 or 316SS for 4X)
MOUNTING SCREW TORQUE:	1.2~1.8N-m (0.9~1.3 Lb-Ft)
INCOMING POWER WIRE SIZE:	0.5 ~ 4.0 sq mm / 20-12AWG
WIRE STRIP LENGTH:	10 ~ 11 mm

MENCOM CORPORATION

TITLE: SMPLX; USB-BA; 16

SIZE <b>B</b>	DWG. NO. DP1-USB-BFAF-16LS	REV <b>E</b>
SCALE: 1:1	WEIGHT:	SHEET 1 OF 1