

8 7 6 5 4 3 2 1

D

C

B

A

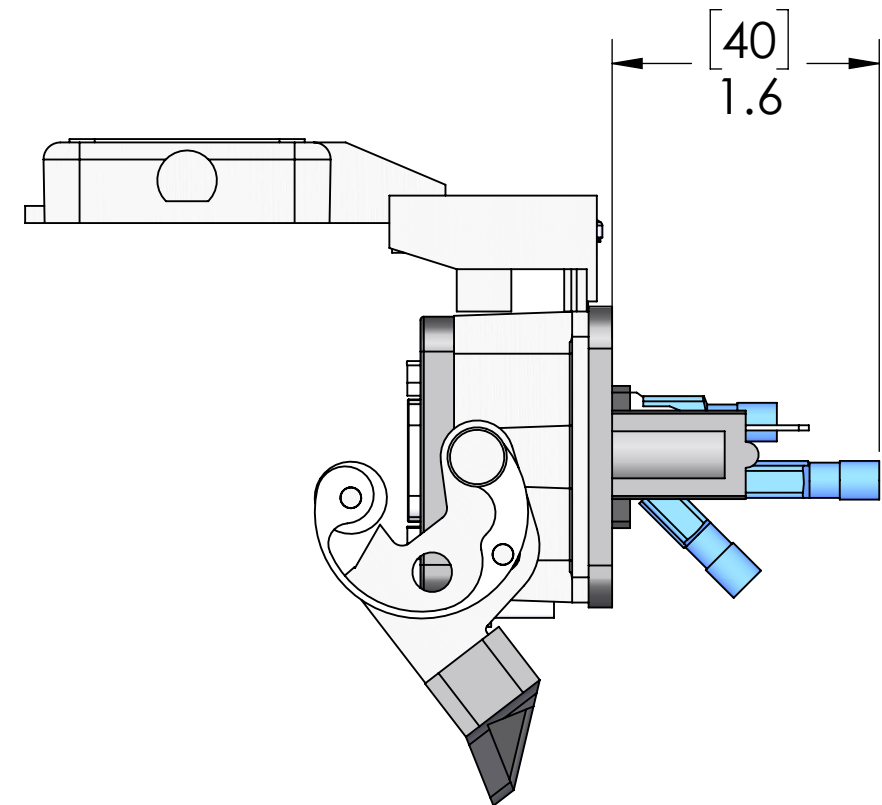
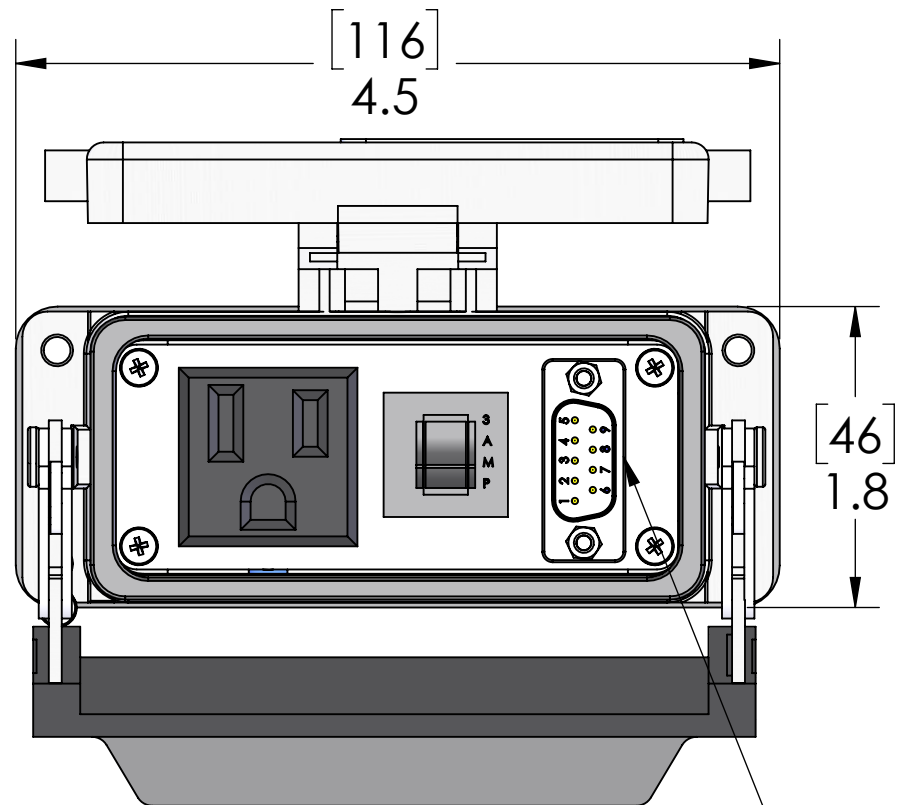

9 PIN D-SUB CONFIGURED
MALE EXTERIOR /
FEMALE INTERIOR

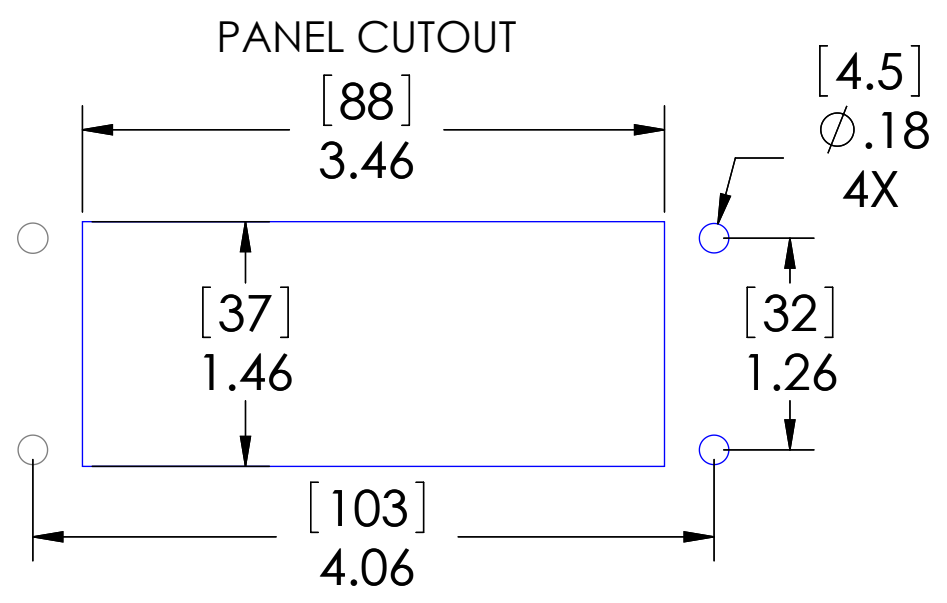

For power connector, crimp terminals are supplied for hot, neutral and ground connections.

These devices shall be mounted on enclosures having adequate strength and thickness and with adequate spacing provided. Seal rating is based on mounting to a surface that is clean, flat and smooth.

HOUSING MATERIALS	
BODY:	EPOXY COATED DIE CAST ALUMINUM
GASKET:	THERMOPLASTIC ELASTOMER
HANDLE:	POLYAMIDE
LEVERS:	STAINLESS STEEL

PIC RATINGS/SPECIFICATIONS	
VOLTS:	125V
AMPS:	3A
SCCR:	0.2kA
NEMA/UL EN 60529:	4, 4X, 12 IP65
MOUNTING SCREW SIZE:	M4 (8-32) (304 or 316SS for 4X)
MOUNTING SCREW TORQUE:	1.2~1.8N-m (0.9~1.3 Lb-Ft)
INCOMING POWER WIRE SIZE:	0.5 ~ 4.0 sq mm / 20-12AWG
WIRE STRIP LENGTH:	10 ~ 11 mm

OPERATING TEMPERATURE: (-10°C / +60° C (+14° F / +140° F))

MOUNTING KIT ORDERED SEPARATELY CONTAINS M4x0.7 SS SCREW, NYLON WASHER, SPLIT LOCKWASHER AND M4 NUT
P/N: D-PIC-MT



UNLESS OTHERWISE SPECIFIED:

DIMENSIONS ARE IN INCHES AND [MM]

PROPRIETARY AND CONFIDENTIAL
THE INFORMATION CONTAINED IN THIS DRAWING IS THE SOLE PROPERTY OF MENCOM CORPORATION. ANY REPRODUCTION IN PART OR AS A WHOLE WITHOUT THE WRITTEN PERMISSION OF MENCOM CORPORATION IS PROHIBITED.

MATERIAL	
FINISH	
DO NOT SCALE DRAWING	

DRAWN BY	DCG
DRAWN DATE	07/12/2021
CHECKED BY	DCG
CHECK DATE	07/13/2021

COMMENTS:

MENCOM CORPORATION

TITLE:
SMPX;DB9 MALE OUT;3A;16

SIZE	DWG. NO.	REV
B	DP1-MDB9-R-16LS	C

SCALE: 7:8	WEIGHT:	SHEET 1 OF 1
------------	---------	--------------

8 7 6 5 4 3 2 1