

REVISIONS			
REV.	DESCRIPTION	DATE	APPROVED
A	REDRAWN IN SW	11/04/2005	BEM

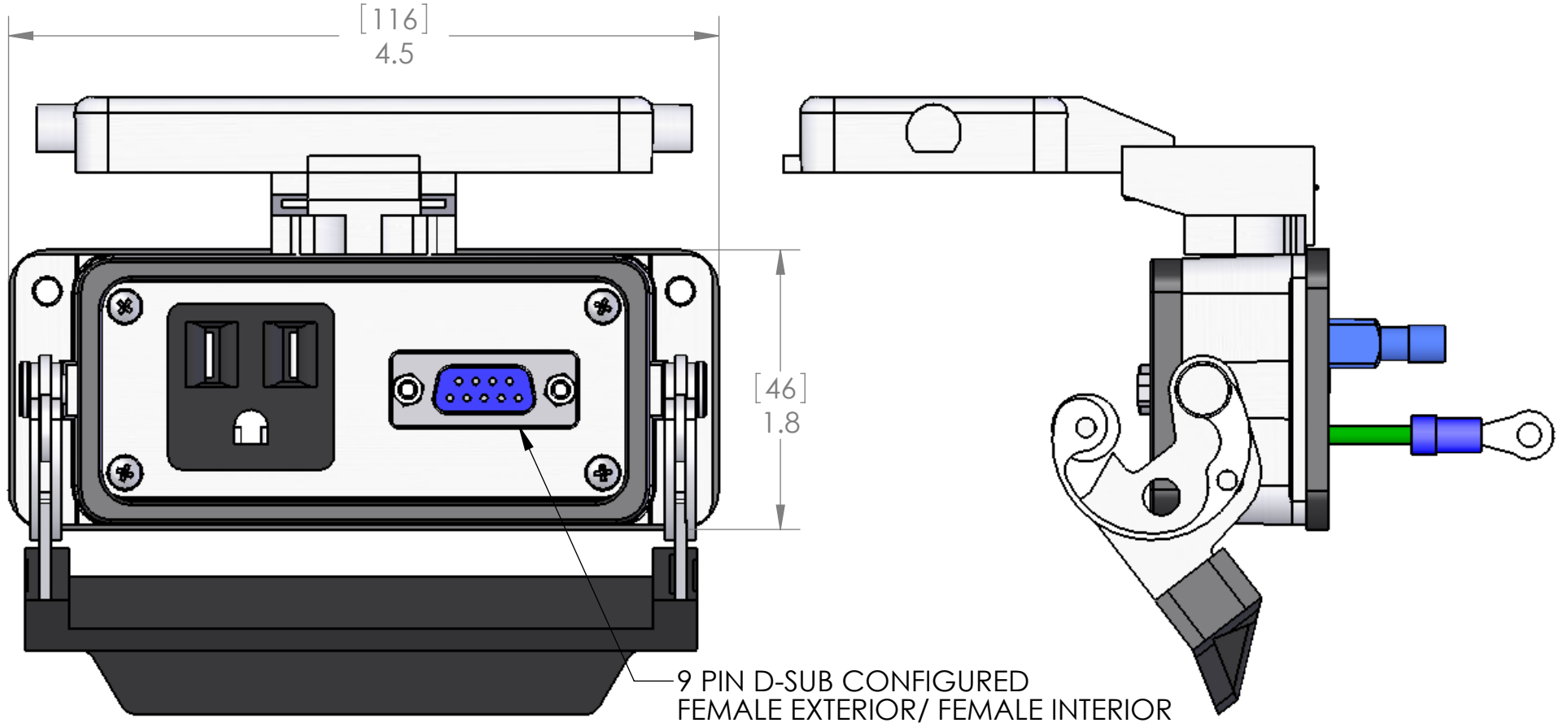
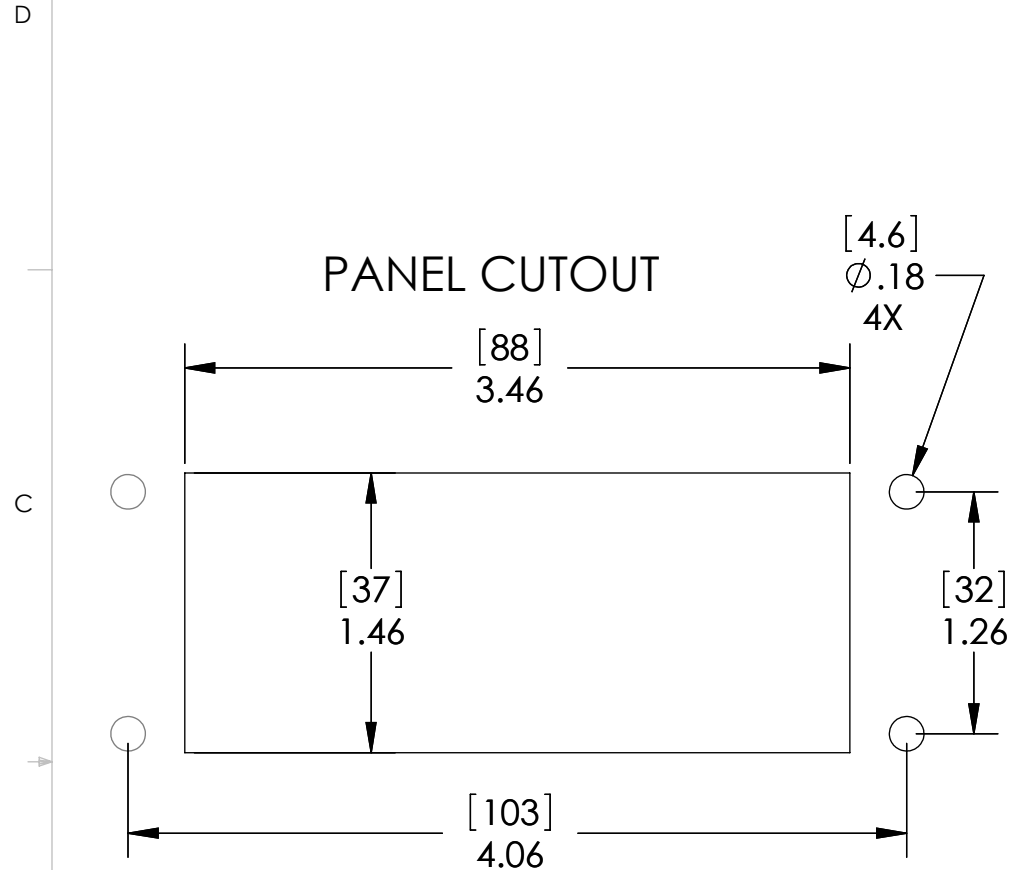

For power connector, crimp terminals are supplied for hot and neutral connection. Ground wire supplied with an M3 ring terminal applied to end of 6" ground lead.

HOUSING MATERIALS	
BODY:	EPOXY COATED DIE CAST ALUMINUM
GASKET:	THERMOPLASTIC ELASTOMER
HANDLE:	POLYAMIDE
LEVERS:	STAINLESS STEEL

APPROVALS	
US:	UL RECOGNIZED
CANADA:	C-UL RECOGNIZED

PIC RATINGS	
VOLTS:	125V
AMPS:	15A
SCCR:	10kA
NEMA/UL:	4, 4X, 12

**PROPRIETARY AND CONFIDENTIAL**  
 THE INFORMATION CONTAINED IN THIS DRAWING IS THE SOLE PROPERTY OF MENCOM CORPORATION. ANY REPRODUCTION IN PART OR AS A WHOLE WITHOUT THE WRITTEN PERMISSION OF MENCOM CORPORATION IS PROHIBITED.

UNLESS OTHERWISE SPECIFIED:	NAME	DATE
DIMENSIONS ARE IN INCHES & [MM]	DRAWN	CAM
	CHECKED	
	ENG APPR.	
	MFG APPR.	
	Q.A.	
	COMMENTS:	

MENCOM CORPORATION		
TITLE:		
SIZE	DWG. NO.	REV
<b>B</b>	DP1-DB9F-16LS	<b>A</b>
SCALE: 1:1	WEIGHT:	SHEET 1 OF 1

8 7 6 5 4 3 2 1

D

D

C

C

B

B

A

A

8 7 6 5 4 3 2 1