

REVISIONS			
REV.	DESCRIPTION	DATE	APPROVED
A	REDRAWN IN SW	7/26/2005	BEM
B	ADDED APPROVALS TO PRINT	10/8/2012	CAM

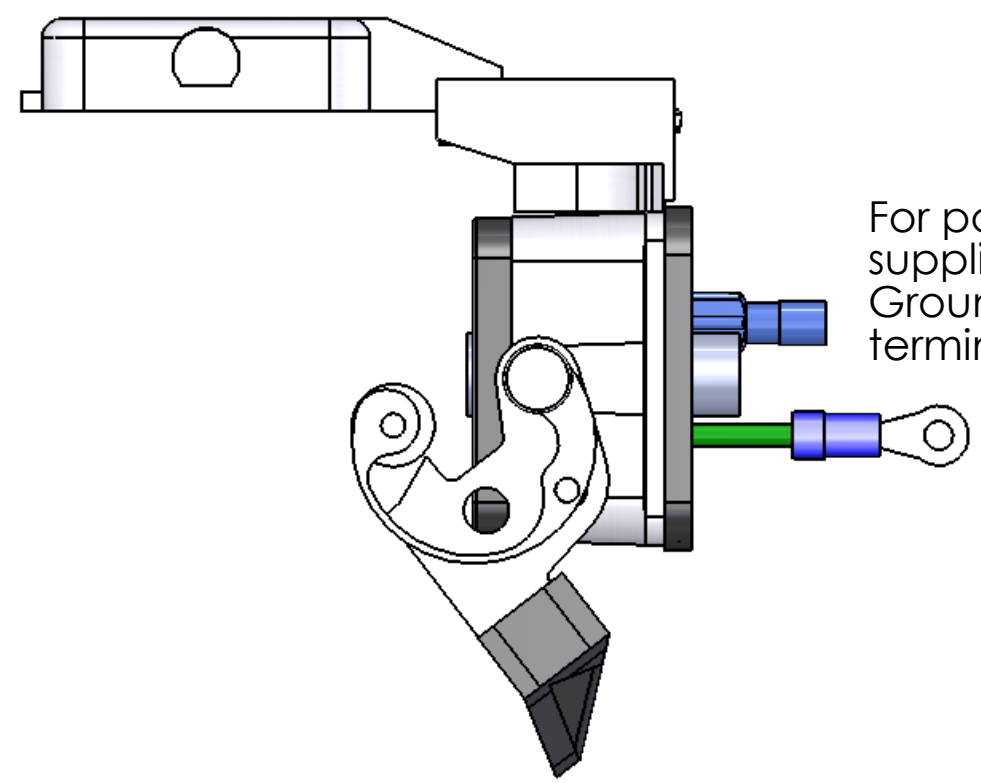

For power connector, crimp terminals are supplied for hot and neutral connection. Ground wire supplied with an M3 ring terminal applied to end of 6" ground lead.

PANEL CUTOUT

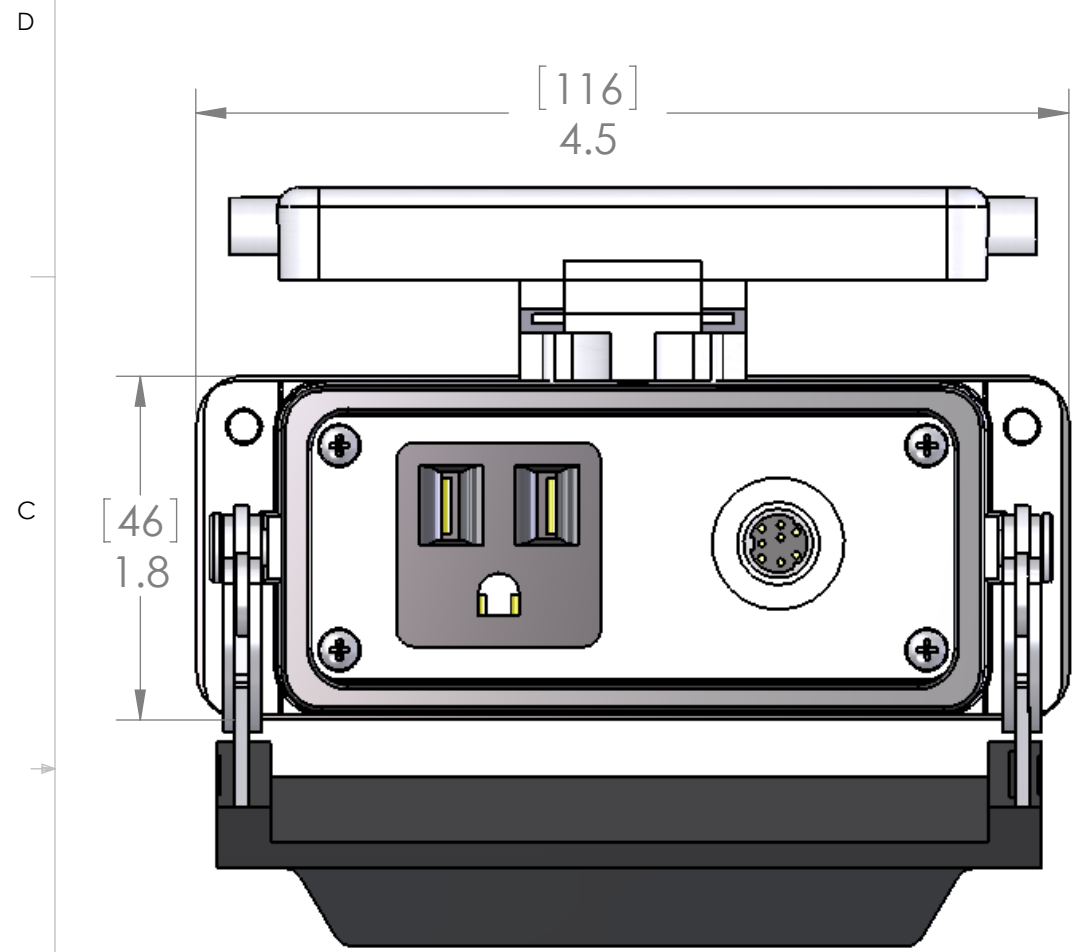
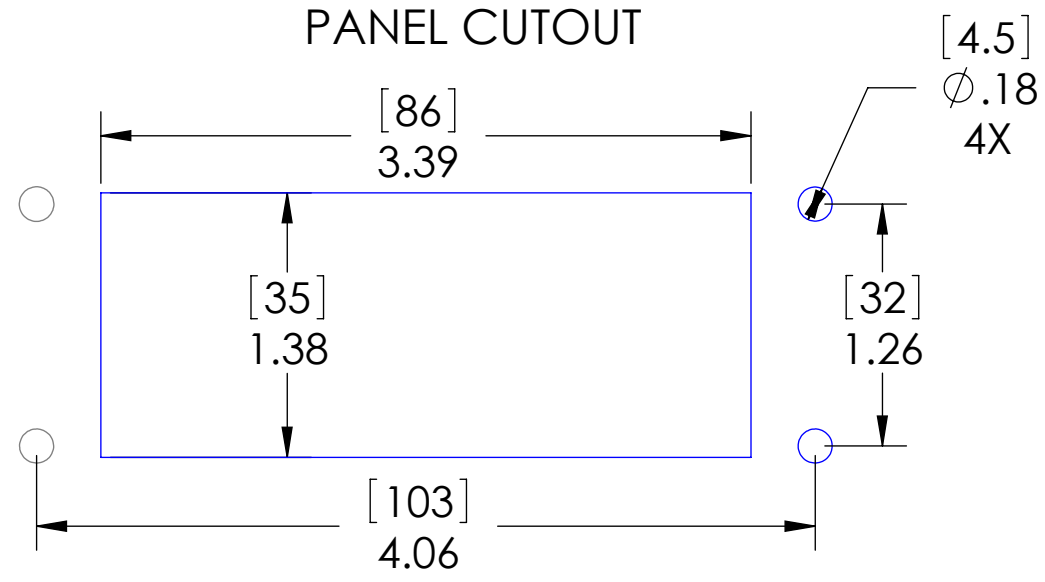

STANDARD CONFIGURATIONS UNLESS OTHERWISE NOTED		
CONN. TYPE	EXTERIOR	INTERIOR
MINI-DINS	FEMALE	FEMALE

PIC RATINGS	
VOLTS:	125V
AMPS:	16A
SCCR:	10kA
NEMA/UL:	4, 4X, 12

UNLESS OTHERWISE SPECIFIED:
 DIMENSIONS ARE IN INCHES AND [MM]
 MATERIAL
 FINISH
 DO NOT SCALE DRAWING

HOUSING MATERIALS	
BODY:	EPOXY COATED DIE CAST ALUMINUM
GASKET:	THERMOPLASTIC ELASTOMER
HANDLE:	POLYAMIDE
LEVERS:	STAINLESS STEEL

APPROVALS	
US	UL RECOGNIZED
CANADA	C-UL RECOGNIZED

NAME		MENCOM CORPORATION	
DRAWN		TITLE:	
CHECKED		SIZE	
ENG APPR.		DWG. NO.	
MFG APPR.		REV	
Q.A.		SCALE: 1:1	
COMMENTS:		WEIGHT:	
		SHEET 1 OF 1	

PROPRIETARY AND CONFIDENTIAL
 THE INFORMATION CONTAINED IN THIS DRAWING IS THE SOLE PROPERTY OF MENCOM CORPORATION. ANY REPRODUCTION IN PART OR AS A WHOLE WITHOUT THE WRITTEN PERMISSION OF MENCOM CORPORATION IS PROHIBITED.