

REVISIONS			
REV.	DESCRIPTION	DATE	APPROVED
A	REDRAWN IN SW	7/26/2006	BEM
B	CHANGED TERMINAL AND WIRES CORRECTED PANEL CUTOUT DIM	11/24/2010	
C	ADDED APPROVALS TO PRINT	10/18/2012	CAM

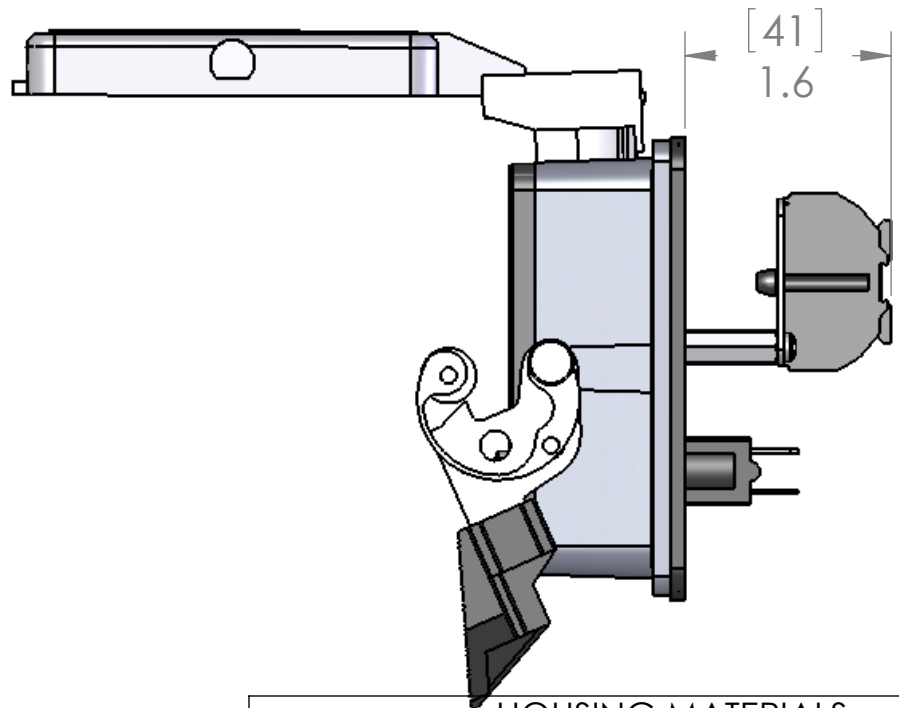
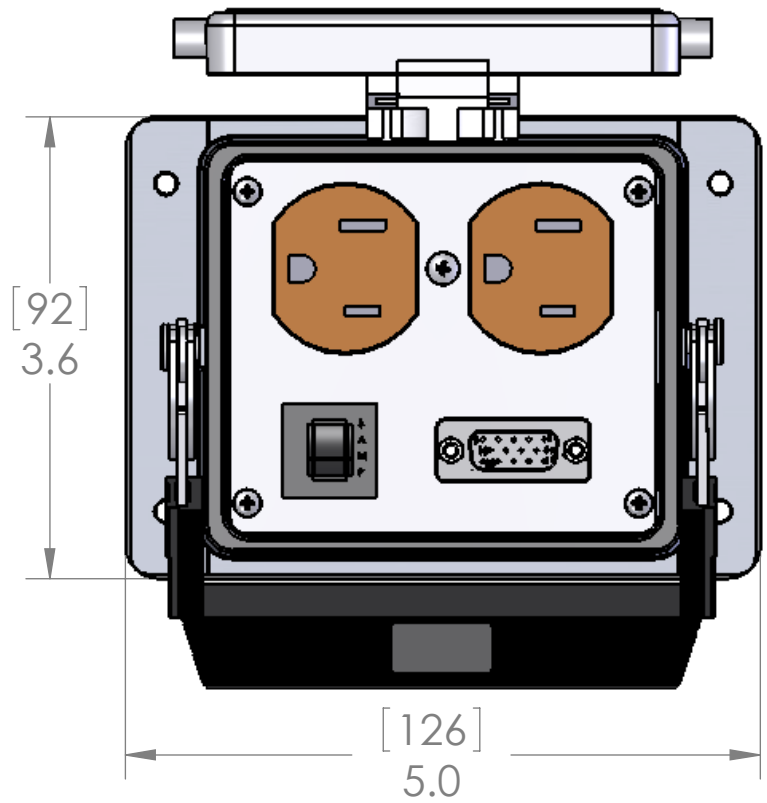
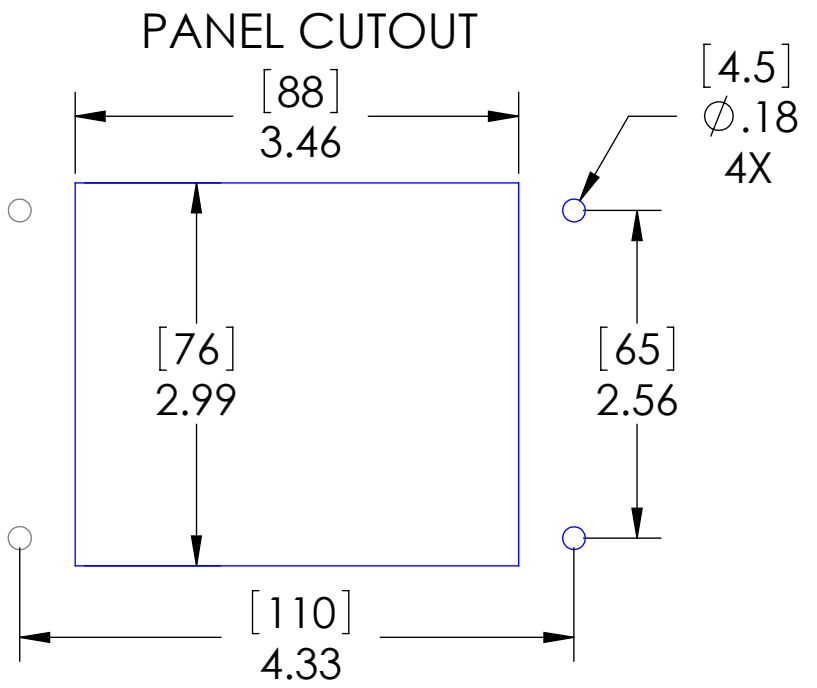

HOUSING MATERIALS	
BODY:	EPOXY COATED DIE CAST ALUMINUM
GASKET:	THERMOPLASTIC ELASTOMER
HANDLE:	POLYAMIDE
LEVERS:	STAINLESS STEEL

APPROVALS	
US	UL RECOGNIZED
CANADA	C-UL RECOGNIZED

PIC RATINGS	
VOLTS:	125V
AMPS:	3A
SCCR:	10kA
NEMA/UL:	4, 4X, 12

UNLESS OTHERWISE SPECIFIED:
DIMENSIONS ARE IN INCHES AND [MM]

MATERIAL

FINISH

DO NOT SCALE DRAWING

MENCOM CORPORATION		
NAME	CAM	
DRAWN	TITLE:	
CHECKED		
ENG APPR.		
MFG APPR.		
Q.A.		
COMMENTS:		
SIZE	DWG. NO.	REV
B	DP-DDB15-R-32	C
SCALE: 2:3	WEIGHT:	SHEET 1 OF 1

STANDARD CONFIGURATIONS UNLESS OTHERWISE NOTED		
CONN. TYPE	EXTERIOR	INTERIOR
ALL D-SUBS	FEMALE	MALE

PROPRIETARY AND CONFIDENTIAL
THE INFORMATION CONTAINED IN THIS DRAWING IS THE SOLE PROPERTY OF MENCOM CORPORATION. ANY REPRODUCTION IN PART OR AS A WHOLE WITHOUT THE WRITTEN PERMISSION OF MENCOM CORPORATION IS PROHIBITED.