

8 7 6 5 4 3 2 1

D  
C  
B  
A

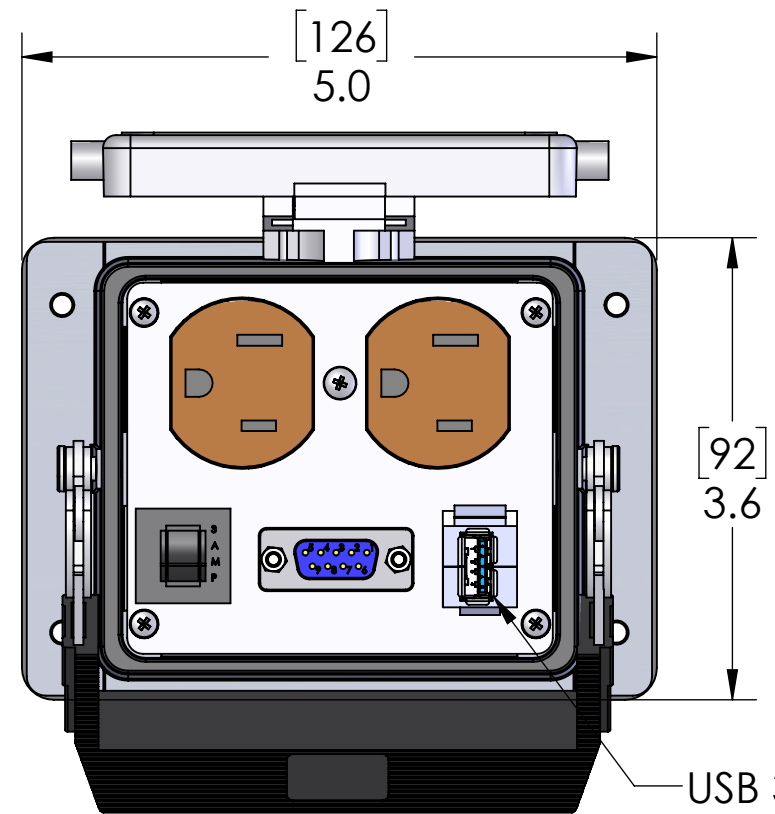

USB 3.0 CONFIGURED  
FEMALE TYPE A EXTERIOR/  
FEMALE TYPE A INTERIOR

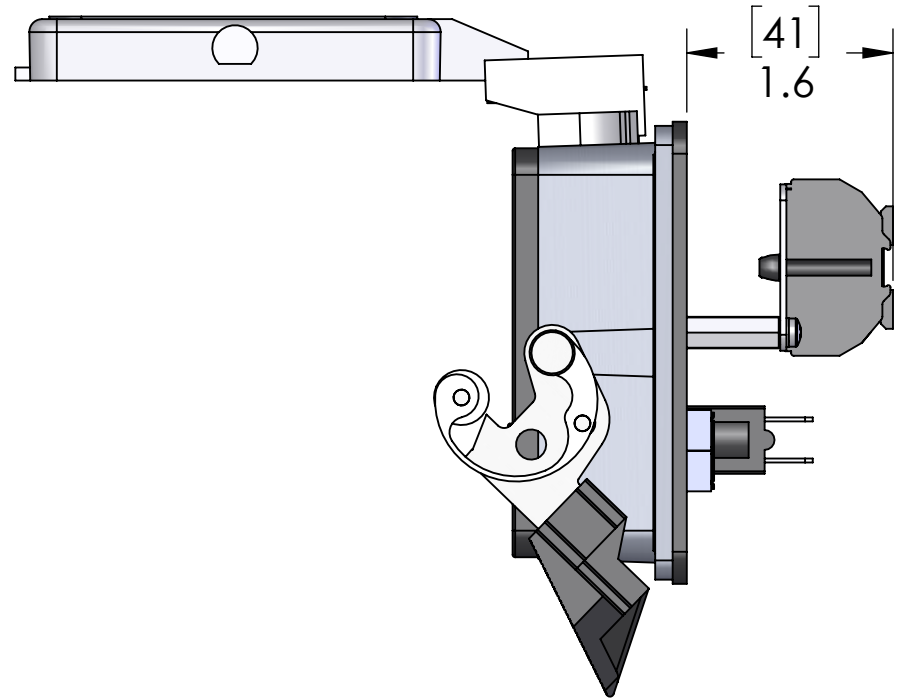

PANEL CUTOUT

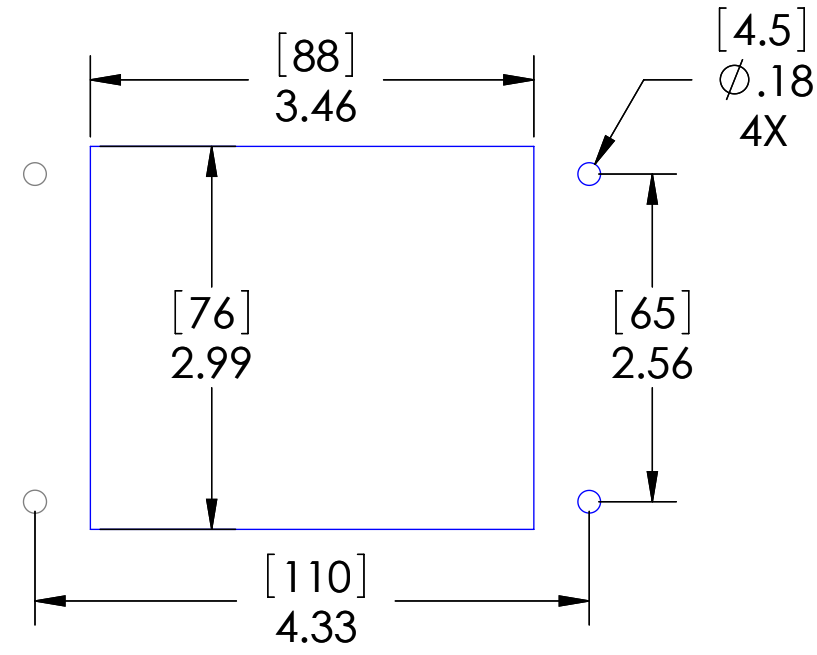

These devices shall be mounted on enclosures having adequate strength and thickness and with adequate spacing provided. Seal rating is based on mounting to a surface that is clean, flat and smooth.

PIC RATINGS/SPECIFICATIONS	
VOLTS:	125V
AMPS:	3A
SCCR:	0.2kA
NEMA/UL   EN 60529:	4, 4X, 12   IP65
MOUNTING SCREW SIZE:	M4 (8-32) (304 or 316SS for 4X)
MOUNTING SCREW TORQUE:	1.2~1.8N-m (0.9~1.3 Lb-Ft)
INCOMING POWER WIRE SIZE:	0.5 ~ 4.0 sq mm / 20-12AWG
WIRE STRIP LENGTH:	10 ~ 11 mm

HOUSING MATERIALS	
BODY:	EPOXY COATED DIE CAST ALUMINUM
GASKET:	THERMOPLASTIC ELASTOMER
HANDLE:	POLYAMIDE
LEVERS:	STAINLESS STEEL

MOUNTING KIT ORDERED SEPARATELY CONTAINS M4x0.7 SS SCREW, NYLON WASHER, SPLIT LOCKWASHER AND M4 NUT  
P/N: D-PIC-MT



UNLESS OTHERWISE SPECIFIED:

DIMENSIONS ARE IN INCHES AND [MM]

MATERIAL  
FINISH  
DO NOT SCALE DRAWING

DRAWN BY:	DCG
DRAWN DATE:	08/06/2020
CHECKED BY:	DCG
CHECK DATE:	08/06/2020

**MENCOM CORPORATION**  
TITLE:  
**DPLX; DB9; USB-AA; 3A; 32**

STANDARD CONFIGURATIONS UNLESS OTHERWISE NOTED		
CONN. TYPE	EXTERIOR	INTERIOR
ALL D-SUBS	FEMALE	MALE

SIZE <b>B</b>	DWG. NO. DP-DB9-USB-AFAF-R-32	REV <b>D</b>
SCALE: 2:3	WEIGHT:	SHEET 1 OF 1

8 7 6 5 4 3 2 1