

INDIA RECEPTACLE (BS 546A)

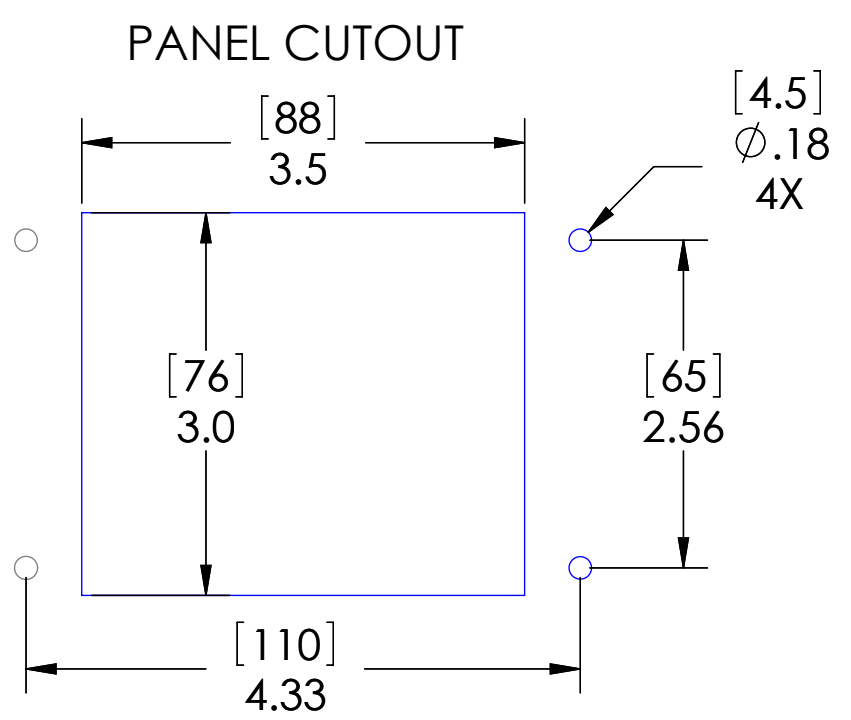
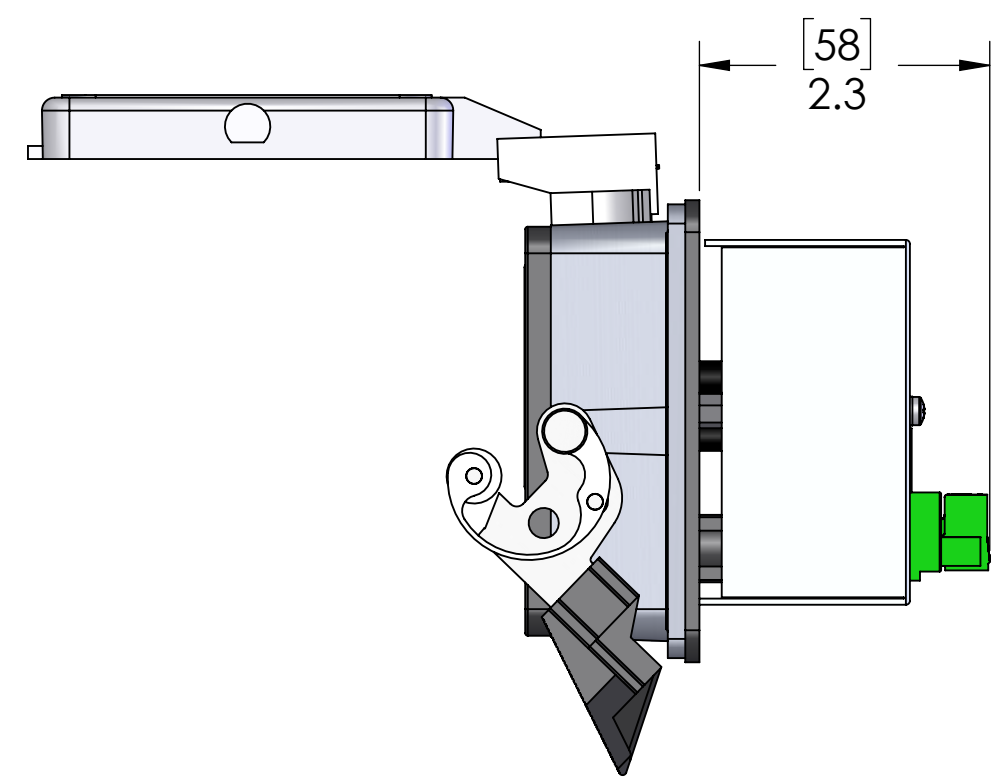

PANEL CUTOUT

These devices shall be mounted on enclosures having adequate strength and thickness and with adequate spacing provided. Seal rating is based on mounting to a surface that is clean, flat and smooth.

HOUSING MATERIALS	
BODY:	EPOXY COATED DIE CAST ALUMINUM
GASKET:	THERMOPLASTIC ELASTOMER
HANDLE:	POLYAMIDE
LEVERS:	STAINLESS STEEL

PIC RATINGS/SPECIFICATIONS	
VOLTS:	250V
AMPS:	3A
SCCR:	0.2kA
NEMA/UL EN 60529:	4, 4X, 12 IP65
MOUNTING SCREW SIZE:	M4 (8-32) (304 or 316SS for 4X)
MOUNTING SCREW TORQUE:	1.2~1.8N-m (0.9~1.3 Lb-Ft)
INCOMING POWER WIRE SIZE:	0.5 ~ 4.0 sq mm / 20-12AWG
WIRE STRIP LENGTH:	10 ~ 11 mm

MOUNTING KIT ORDERED SEPARATELY CONTAINS M5x0.8 SS SCREW, NYLON WASHER, SPLIT LOCKWASHER AND M5 NUT
P/N: D-PIC-MT-M5

PROPRIETARY AND CONFIDENTIAL
 THE INFORMATION CONTAINED IN THIS DRAWING IS THE SOLE PROPERTY OF MENCOM CORPORATION. ANY REPRODUCTION IN PART OR AS A WHOLE WITHOUT THE WRITTEN PERMISSION OF MENCOM CORPORATION IS PROHIBITED.

UNLESS OTHERWISE SPECIFIED:
 DIMENSIONS ARE IN INCHES
 TOLERANCES:
 FRACTIONAL ±1/64
 ANGULAR: MACH ±5° BEND ±5°
 TWO PLACE DECIMAL ±.01
 THREE PLACE DECIMAL ±.004

MATERIAL	
FINISH	
DO NOT SCALE DRAWING	

DRAWN BY	ADM
DRAWN DATE	09/22/2016
CHECKED BY	
CHECK DATE	

MENCOM CORPORATION		
TITLE: DIN;3A;32		
SIZE B	DWG. NO. DIN-R-32	REV A
SCALE: 2:3	WEIGHT:	SHEET 1 OF 1