

ITEM NO.	PART NUMBER	DESCRIPTION	QTY.
1	80CHI32LS-A	RAW CHI-32LS NO LABEL	1
2	80DHPLUG	DATA HIGHWAY 3 POLE PLUG	1
3	80EPX45	MOD 45; 250V; 16A; SCHUKO RCPT	1
4	80GF-RCBO-BRACKET	BRACKET TO LOWER HEIGHT OF GFI RCBO	1
5	80I0001H	BLK 14# WIRE RESET TO 80TB3W	2
6	80I0010	STAND OFF MALE FEMALE 30MM	2
7	80I0026-AA	DATA HIGHWAY 9 PIN BOARD	1
8	80I0136-NON UL	LG FACE PLT; NON-UL; SZ 32 - 48	1
9	80I0458	SM TB PLATE FOR WAGO TB	1
10	80I0535	MOD; DB9; RESET; 32	1
11	80ILG04	GRN UL1569 14AWG 5.5" .25/.41 S&R	1
12	80ILW03	WHITE UL1569	1
13	80LABELTB-BB	250 VAC MAX LABEL FOR WAGO TB	1
14	80R3AMP	3 AMP RESET	1
15	80SM3X10	SCREW M3X10 0.5MM PH W/ SEMS	2
16	80SM3X16	SCREW M3X16 0.5MM PH W/ SEMS	2
17	80SNM3X05	NUT M3 X 0.5	2
18	80SPJS	PCB JACKSCREW	2
19	80SWM3	WASHER LOCK M3 EXT TOOTH	4
20	80TB3W	WAGO 3 POLE TB #862-1533	1
21	BOX	UNIV PIC PACKAGE REF WIP FOR SIZE	1
22	BUBL-0.5-DM2	SEALED AIR 100002065 1/2" DM 2	1.34 FT
23	INST-STD-PIC	BULKHEAD MOUNTED INSTRUCTION MANUAL	1
24	LBL-T300X200	3" X 2" THERMAL LABEL	1
25	LBL-TTPP-200X100	2 X 1 THERMAL LABEL	1

REVISIONS			
REV.	DESCRIPTION	DATE	APPROVED
A	REDRAWN IN SW	8/23/2006	BEM
B	REPLACED TERMINALS, EP RECEPT, AND WIRES TO CURRENT COMPONENTS AND CONFIGURATIONS	5/16/2013	DCT
C	UPDATED PLATE & MOD BRACKET: TB POSITION	8/5/2024	DCG

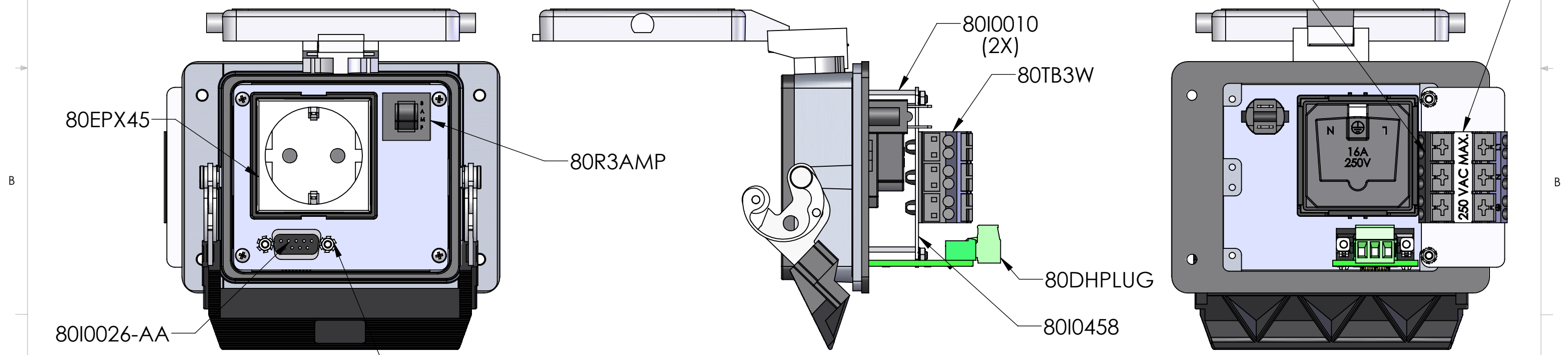

<p>UNLESS OTHERWISE SPECIFIED:</p> <p>DIMENSIONS ARE IN INCHES</p> <p>TOLERANCES:</p> <p>FRACTIONAL ± 1/64</p> <p>ANGULAR: MACH ± 5° BEND ± 5°</p> <p>TWO PLACE DECIMAL ± .01</p> <p>THREE PLACE DECIMAL ± .004</p>	DRAWN BY	ADM	<p>MENCOM CORPORATION</p> <p>TITLE:</p> <p>GERMAN RCP; 9 PIN BLHO; 3A; 32</p>
	DRAWN DATE	08/09/2024	
	CHECKED BY	RP	
	CHECK DATE	08/05/2024	
	COMMENTS:		
	MATERIAL		SIZE B
	FINISH		DWG. NO. DHEP-DB9-R-32
	DO NOT SCALE DRAWING		REV C
			SCALE: 2:3
			WEIGHT:
			SHEET 1 OF 1

PROPRIETARY AND CONFIDENTIAL

THE INFORMATION CONTAINED IN THIS DRAWING IS THE SOLE PROPERTY OF MENCOM CORPORATION. ANY REPRODUCTION IN PART OR AS A WHOLE WITHOUT THE WRITTEN PERMISSION OF MENCOM CORPORATION IS PROHIBITED.