

9 PIN D-SUB IS CONNECTED TO A THREE PIN PLUGGABLE TERMINAL BLOCK FOR BLUE HOSE APPLICATION

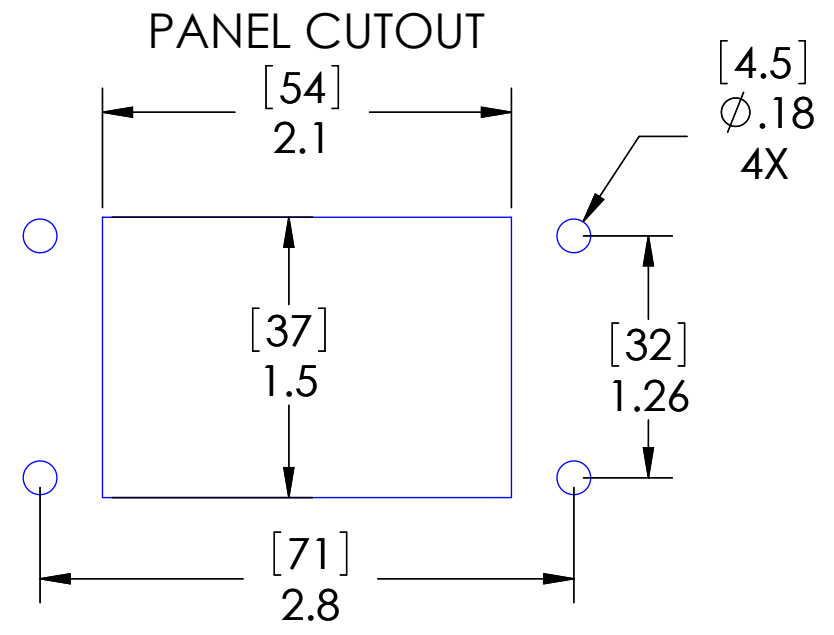
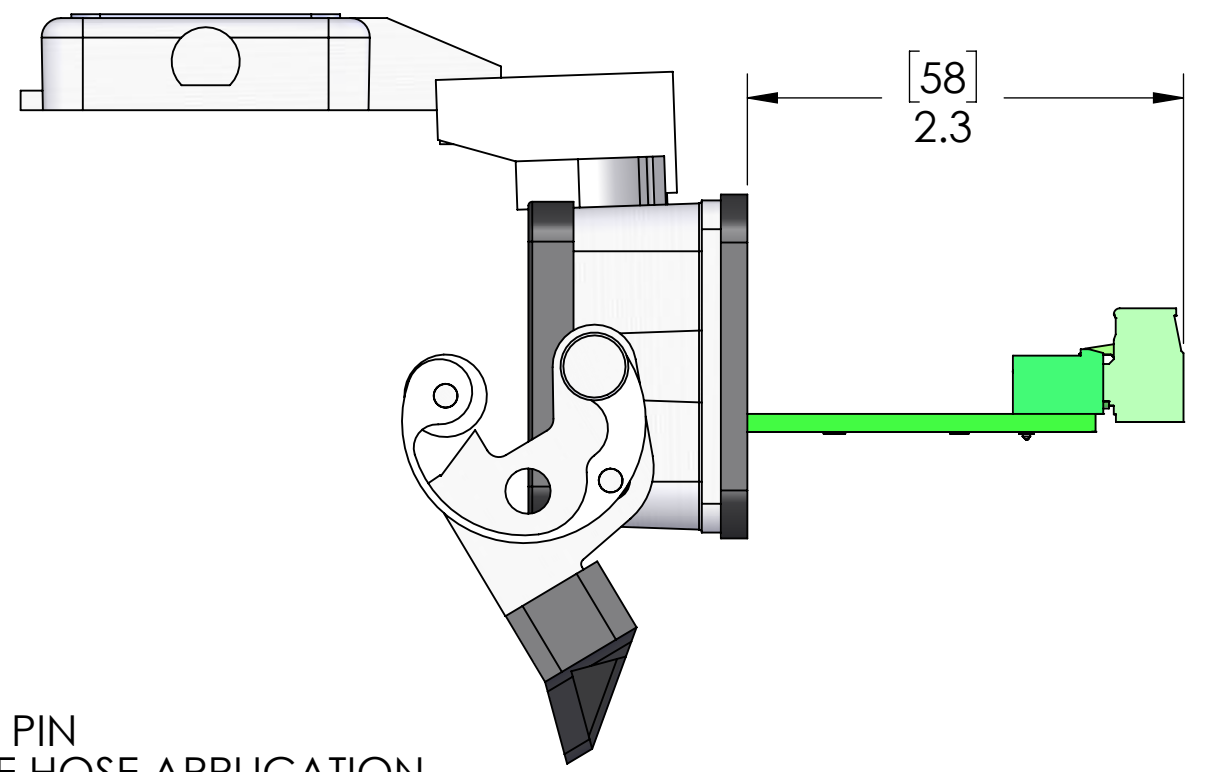

These devices shall be mounted on enclosures having adequate strength and thickness and with adequate spacing provided. Seal rating is based on mounting to a surface that is clean, flat and smooth.

| HOUSING MATERIALS |                                |
|-------------------|--------------------------------|
| BODY:             | EPOXY COATED DIE CAST ALUMINUM |
| GASKET:           | THERMOPLASTIC ELASTOMER        |
| HANDLE:           | POLYAMIDE                      |
| LEVERS:           | STAINLESS STEEL                |

| PIC RATINGS/SPECIFICATIONS |                                 |
|----------------------------|---------------------------------|
| NEMA/UL   EN 60529:        | 4, 4X, 12   IP65                |
| MOUNTING SCREW SIZE:       | M4 (8-32) (304 or 316SS for 4X) |
| MOUNTING SCREW TORQUE:     | 1.2~1.8N-m (0.9~1.3 Lb-Ft)      |
| INCOMING POWER WIRE SIZE:  | 0.5 ~ 4.0 sq mm / 20-12AWG      |
| WIRE STRIP LENGTH:         | 10 ~ 11 mm                      |

MOUNTING KIT ORDERED SEPARATELY CONTAINS M4x0.7 SS SCREW, NYLON WASHER, SPLIT LOCKWASHER AND M4 NUT  
**P/N: D-PIC-MT**



UNLESS OTHERWISE SPECIFIED:

|                      |            |
|----------------------|------------|
| DRAWN BY             | DCG        |
| DRAWN DATE           | 09/22/2016 |
| CHECKED BY           |            |
| CHECK DATE           |            |
| COMMENTS:            |            |
| MATERIAL             |            |
| FINISH               |            |
| DO NOT SCALE DRAWING |            |

**MENCOM CORPORATION**

TITLE:  
 SZ6; DH 9 PIN FOR B.H

SIZE **B** DWG. NO. DH-DB9-06LS REV **A**

SCALE: 1:1 WEIGHT: SHEET 1 OF 1

**PROPRIETARY AND CONFIDENTIAL**  
 THE INFORMATION CONTAINED IN THIS DRAWING IS THE SOLE PROPERTY OF MENCOM CORPORATION. ANY REPRODUCTION IN PART OR AS A WHOLE WITHOUT THE WRITTEN PERMISSION OF MENCOM CORPORATION IS PROHIBITED.