

REVISIONS			
REV.	DESCRIPTION	DATE	APPROVED
A	REDRAWN IN SW	10/7/2005	BEM
B	MODIFIED PANEL CUTOUT DIM	6/29/2012	CAM

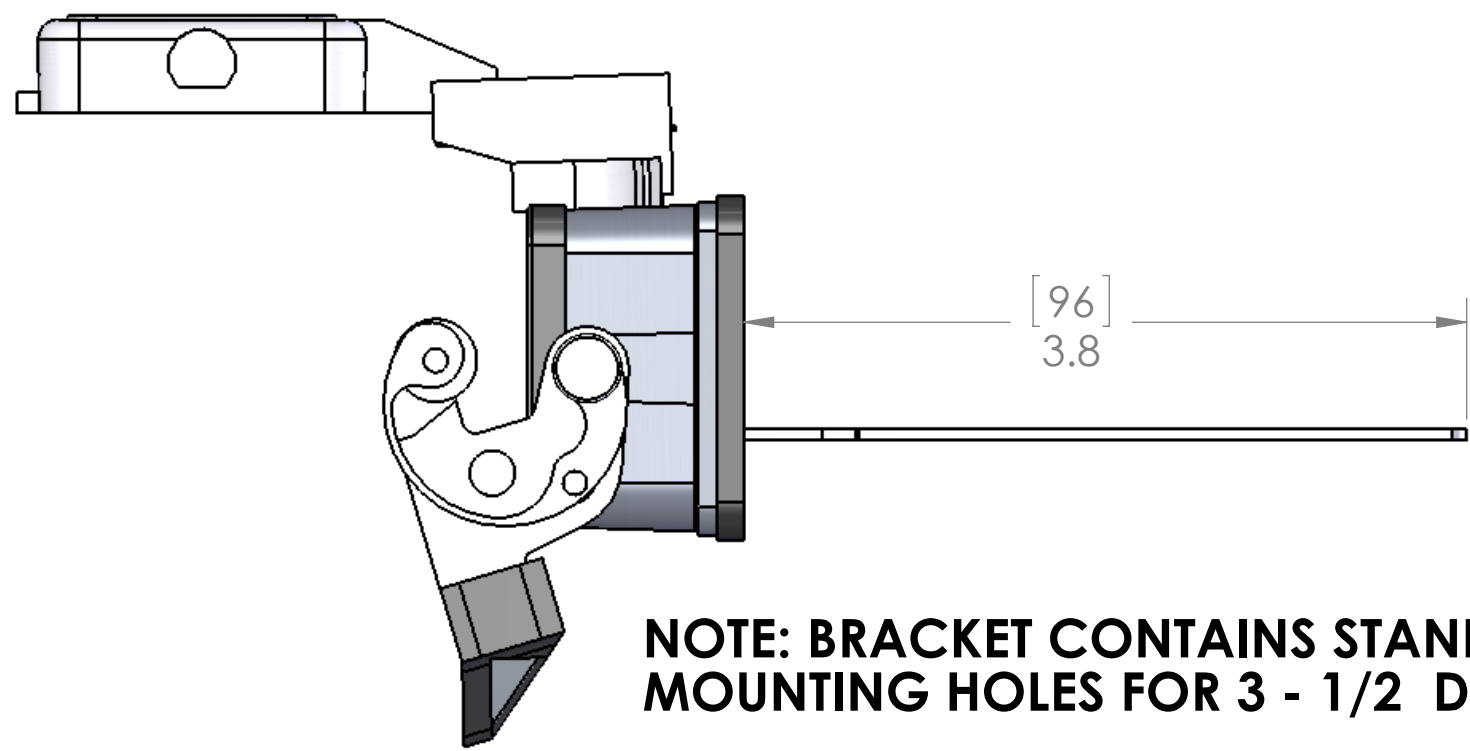

**NOTE: BRACKET CONTAINS STANDARD MOUNTING HOLES FOR 3 - 1/2 DRIVES**

**PANEL CUTOUT**

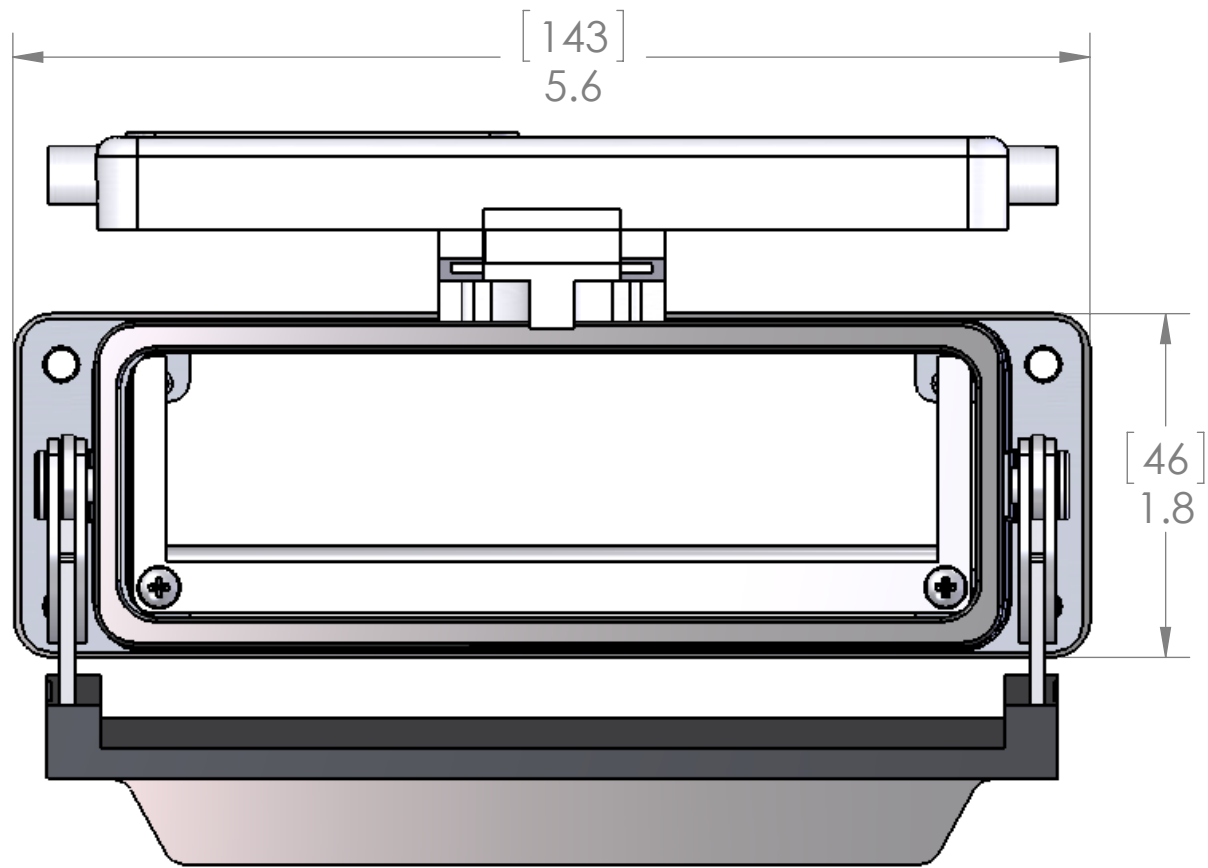
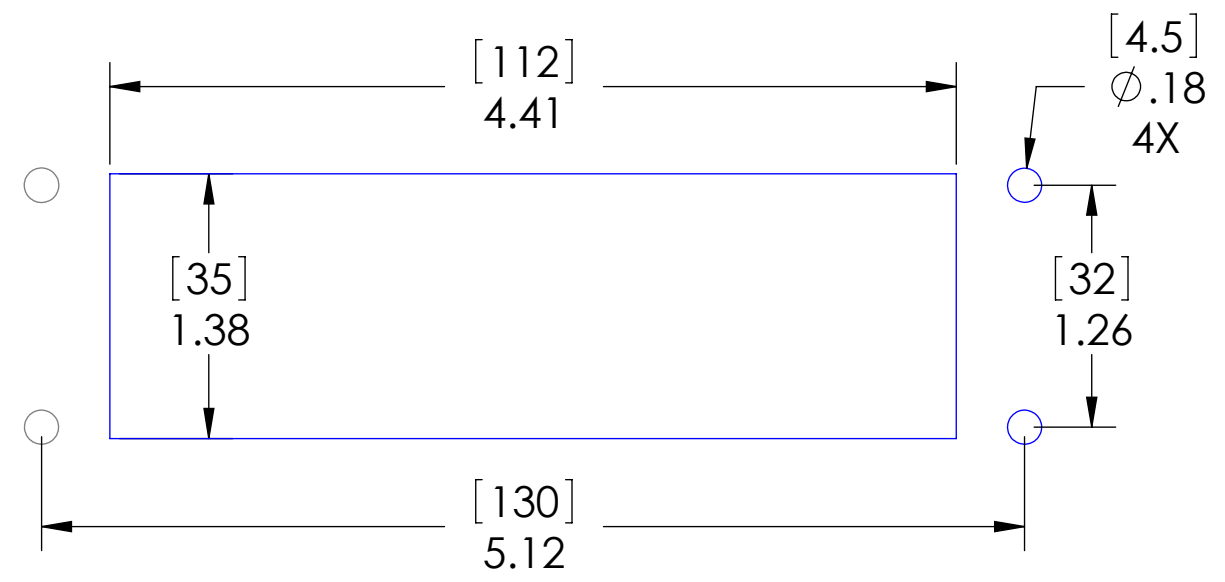

HOUSING MATERIALS	
BODY:	EPOXY COATED DIE CAST ALUMINUM
GASKET:	THERMOPLASTIC ELASTOMER
HANDLE:	POLYAMIDE
LEVERS:	STAINLESS STEEL

UNLESS OTHERWISE SPECIFIED:  
 DIMENSIONS ARE IN INCHES AND [MM]  
 MATERIAL  
 FINISH  
 DO NOT SCALE DRAWING

	NAME
DRAWN	CAM
CHECKED	
ENG APPR.	
MFG APPR.	
Q.A.	
COMMENTS:	

**MENCOM CORPORATION**  
 TITLE:

**PROPRIETARY AND CONFIDENTIAL**  
 THE INFORMATION CONTAINED IN THIS DRAWING IS THE SOLE PROPERTY OF MENCOM CORPORATION. ANY REPRODUCTION IN PART OR AS A WHOLE WITHOUT THE WRITTEN PERMISSION OF MENCOM CORPORATION IS PROHIBITED.

SIZE <b>B</b>	DWG. NO. DFD-24LS-KIT	REV <b>B</b>
SCALE: 1:1	WEIGHT:	SHEET 1 OF 1