

REVISIONS			
REV.	DESCRIPTION	DATE	APPROVED
A	REDRAWN IN SW	2/3/2006	BEM
B	SEE NOTES	3/31/2008	BEM
C	UPDATED TO USB 3.0	4/25/2016	JJH

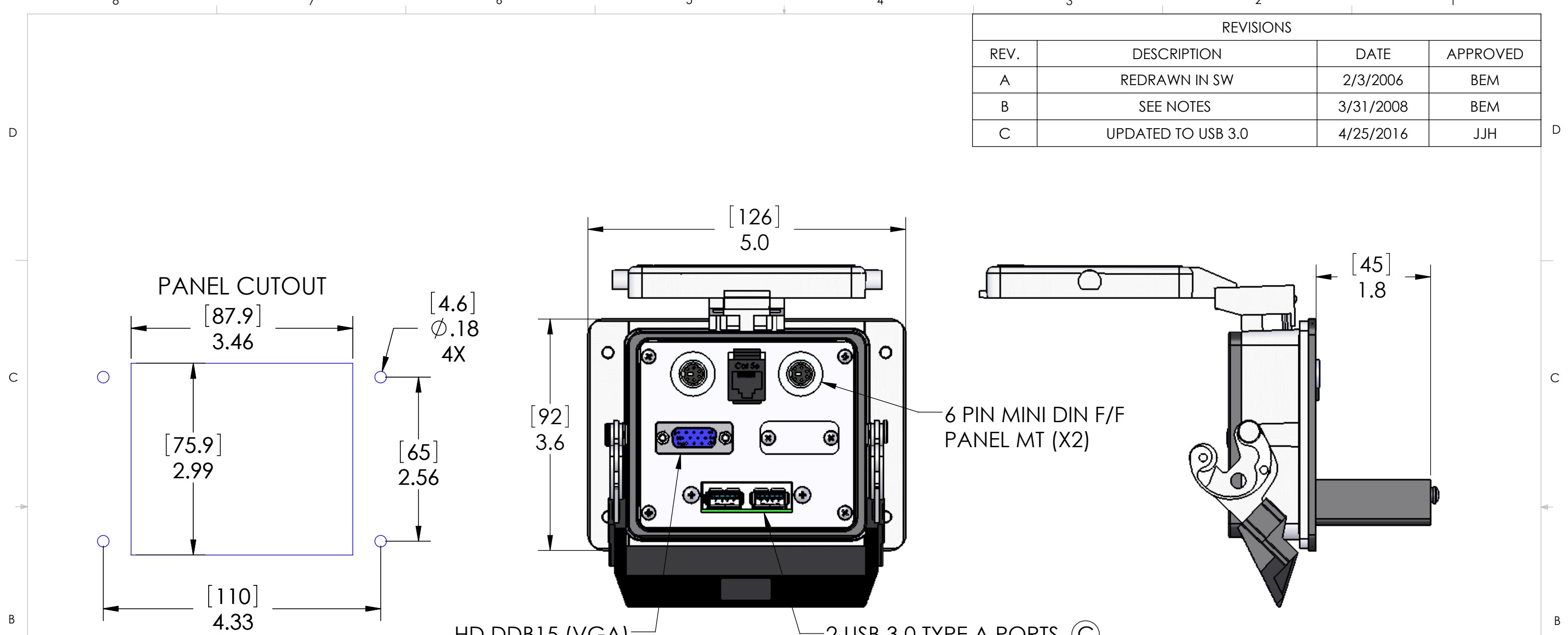

HD DDB15 (VGA) 2 USB 3.0 TYPE A PORTS ♻️ FEMALE TO FEMALE

HOUSING MATERIALS	
BODY:	EPOXY COATED DIE CAST ALUMINUM
GASKET:	THERMOPLASTIC ELASTOMER
HANDLE:	POLYAMIDE
LEVERS:	STAINLESS STEEL

APPROVALS	
US:	UL RECOGNIZED
CANADA:	C-UL RECOGNIZED

STANDARD CONFIGURATIONS UNLESS OTHERWISE NOTED		
CONN. TYPE	EXTERIOR	INTERIOR
MINI-DINS	FEMALE	FEMALE
RJ45	CAT 5 JACK	CAT 5 JACK
D-SUB	FEMALE	MALE

PIC RATINGS	
NEMA/UL:	4, 4X, 12

PROPRIETARY AND CONFIDENTIAL
 THE INFORMATION CONTAINED IN THIS DRAWING IS THE SOLE PROPERTY OF MENCOM CORPORATION. ANY REPRODUCTION IN PART OR AS A WHOLE WITHOUT THE WRITTEN PERMISSION OF MENCOM CORPORATION IS PROHIBITED.

UNLESS OTHERWISE SPECIFIED:
 DIMENSIONS ARE IN INCHES & [MM]
 MATERIAL
 FINISH
 DO NOT SCALE DRAWING

NAME	NAME
DRAWN	CAM
CHECKED	
ENG APPR.	
MFG APPR.	
Q.A.	
COMMENTS:	

MENCOM CORPORATION		
TITLE: HD15;USB;RJ45;2-6 MINI DIN		
SIZE	DWG. NO.	REV
B	DDB15-USB-RJ45-6M2-32	C
SCALE: 2:3	WEIGHT:	SHEET 1 OF 1