

8 7 6 5 4 3 2 1

D
C
B
A

D
C
B
A

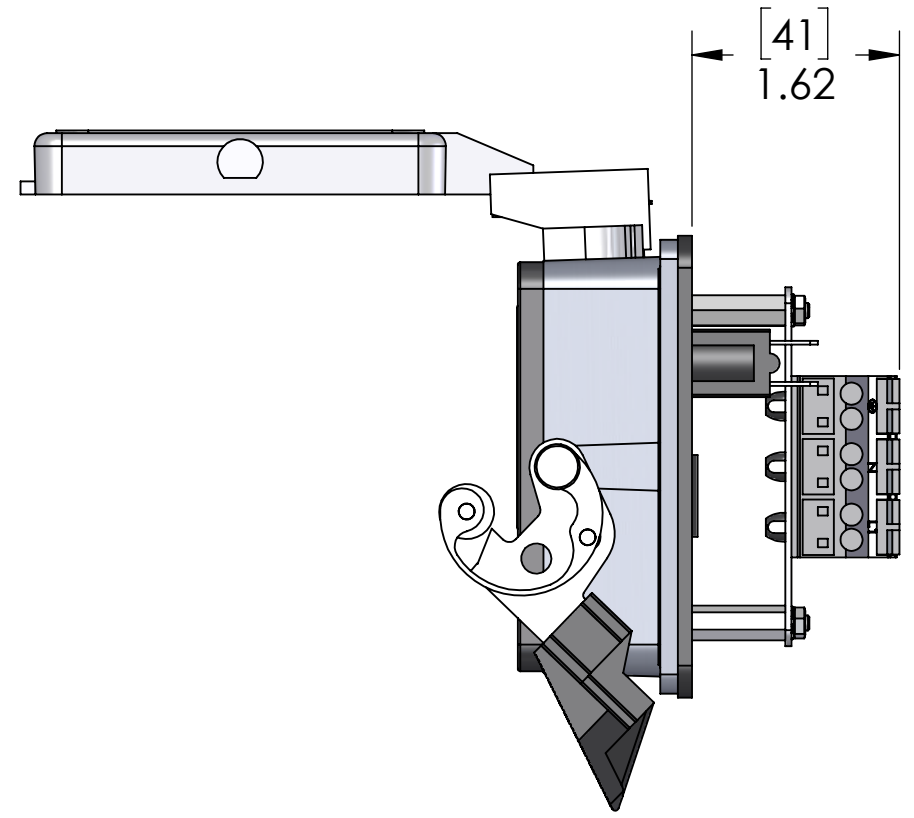
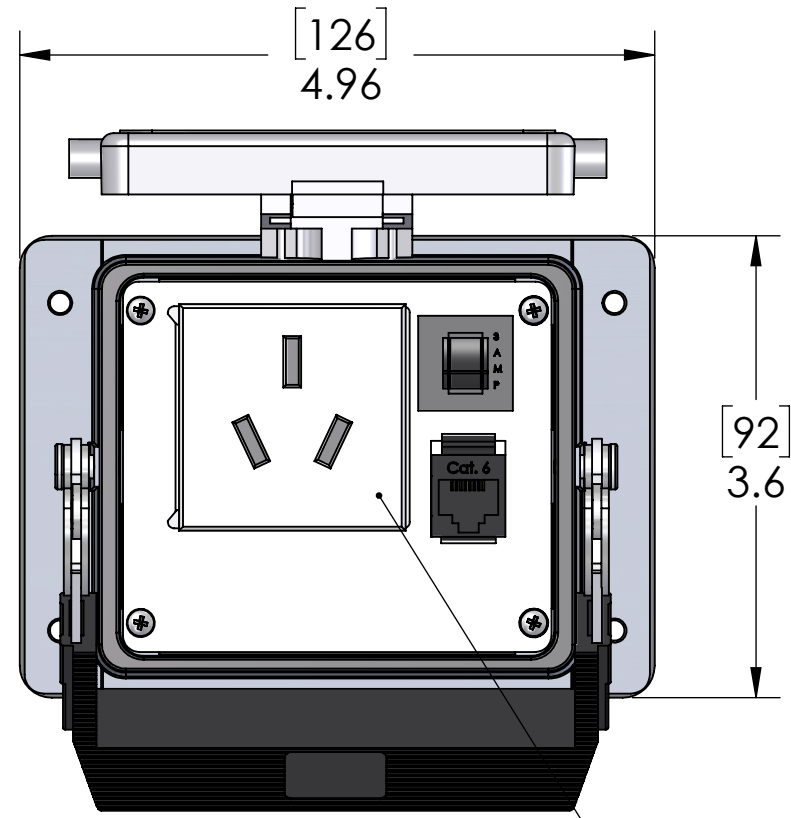

CH2-16R CHINESE RECEPTACLE
16A, 250V, CCC CERTIFICATION

PANEL CUTOUT

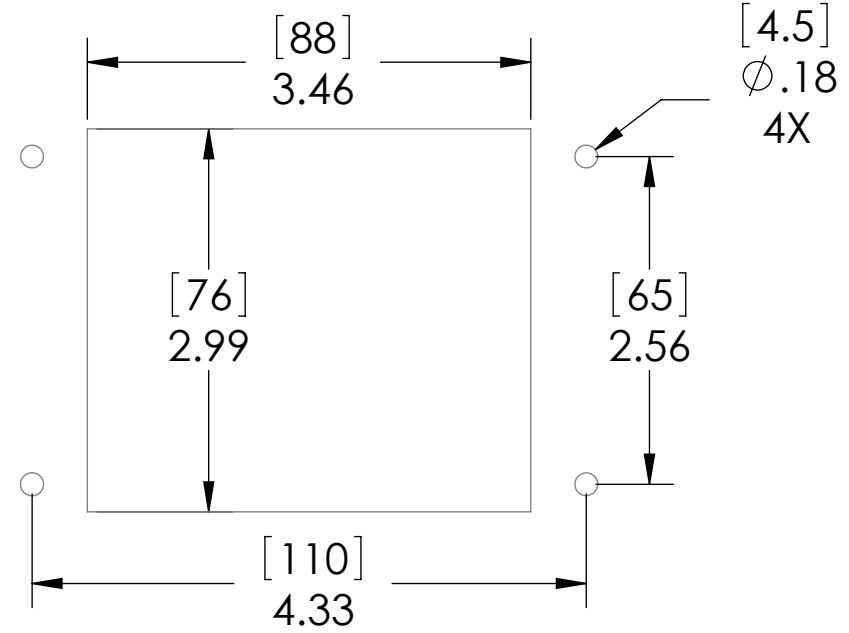

These devices shall be mounted on enclosures having adequate strength and thickness and with adequate spacing provided. Seal rating is based on mounting to a surface that is clean, flat and smooth.

PIC RATINGS/SPECIFICATIONS	
VOLTS:	250V
AMPS:	3A
NEMA/UL EN 60529:	4, 4X, 12 IP65
MOUNTING SCREW SIZE:	M4 (8-32) (304 or 316SS for 4X)
MOUNTING SCREW TORQUE:	1.2~1.8N-m (0.9~1.3 Lb-Ft)
INCOMING POWER WIRE SIZE:	0.5 ~ 4.0 sq mm / 20-12AWG
WIRE STRIP LENGTH:	10 ~ 11 mm

HOUSING MATERIALS	
BODY:	EPOXY COATED DIE CAST ALUMINUM
GASKET:	THERMOPLASTIC ELASTOMER
HANDLE:	POLYAMIDE
LEVERS:	STAINLESS STEEL

OPERATING TEMPERATURE: (-5°C / +50° C (+23° F / +122° F))

MOUNTING KIT ORDERED SEPARATELY CONTAINS M4x0.7 SS SCREW, NYLON WASHER, SPLIT LOCKWASHER AND M4 NUT
P/N: D-PIC-MT

UNLESS OTHERWISE SPECIFIED:	DRAWN BY	APR
DIMENSIONS ARE IN INCHES AND [MM]	DRAWN DATE	09/22/2016
	CHECKED BY	
	CHECK DATE	
	COMMENTS:	
MATERIAL		
FINISH		
DO NOT SCALE DRAWING		

MENCOM CORPORATION

TITLE:
CHINA 16A RCPT;RJ45;3A;32

STANDARD CONFIGURATIONS UNLESS OTHERWISE NOTED		
CONN. TYPE	EXTERIOR	INTERIOR
RJ45	CAT 6 JACK	CAT 6 JACK

PROPRIETARY AND CONFIDENTIAL
THE INFORMATION CONTAINED IN THIS DRAWING IS THE SOLE PROPERTY OF MENCOM CORPORATION. ANY REPRODUCTION IN PART OR AS A WHOLE WITHOUT THE WRITTEN PERMISSION OF MENCOM CORPORATION IS PROHIBITED.

SIZE	DWG. NO.	REV
B	DCH2-RJ45-R-32	D
SCALE: 2:3	WEIGHT:	SHEET 1 OF 1

8 7 6 5 4 3 2 1