

8 7 6 5 4 3 2 1

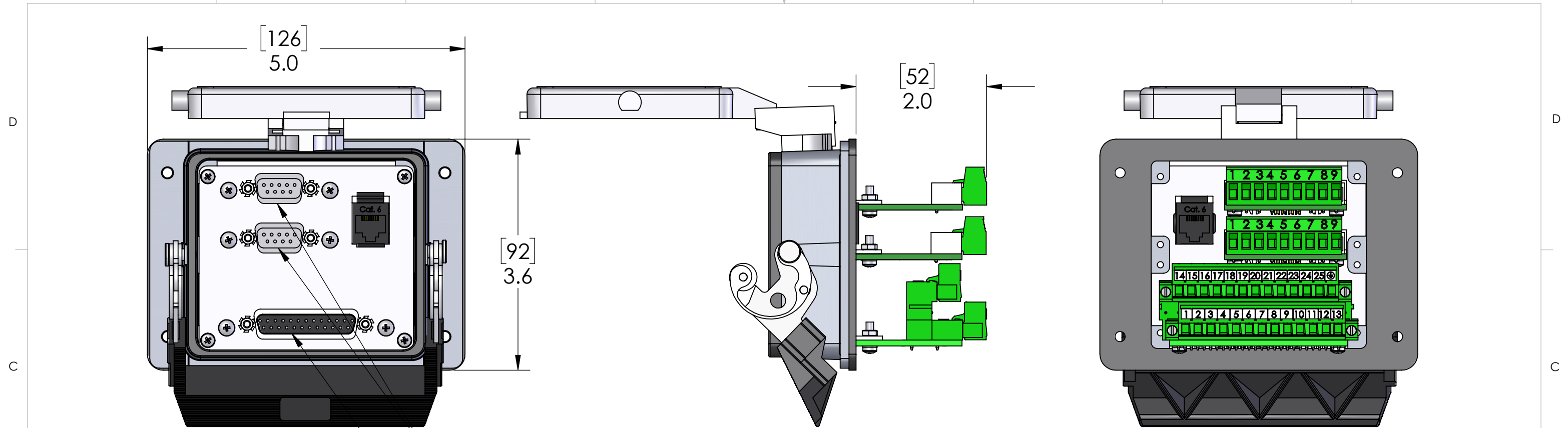

FEMALE 9 PIN D-SUB (2X)
FEMALE 25 PIN D-SUB

ALL D-SUBS ARE WIRED BACK TO A PLUGGABLE TERMINAL BLOCKS, BOTH PLUG AND SOCKET ARE SUPPLIED WITH UNIT

PANEL CUTOUT

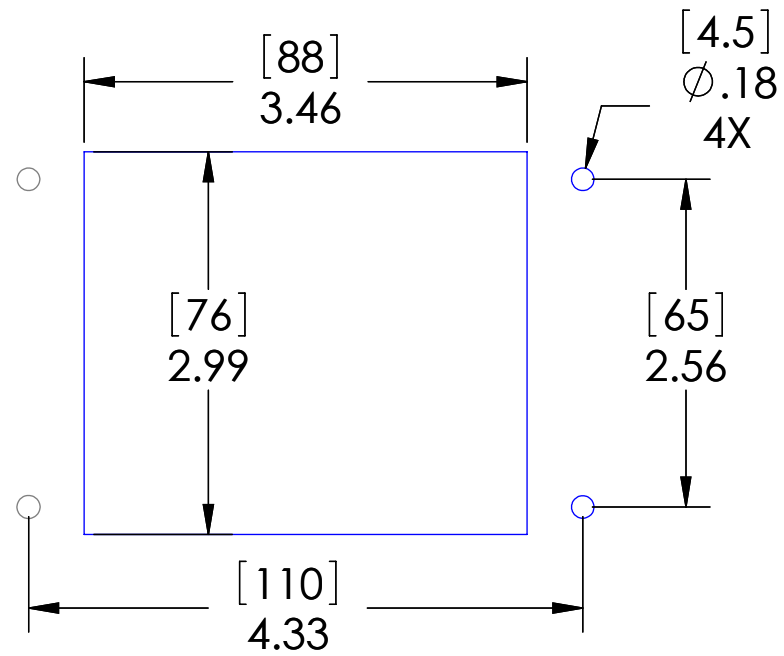

These devices shall be mounted on enclosures having adequate strength and thickness and with adequate spacing provided. Seal rating is based on mounting to a surface that is clean, flat and smooth.

HOUSING MATERIALS	
BODY:	EPOXY COATED DIE CAST ALUMINUM
GASKET:	THERMOPLASTIC ELASTOMER
HANDLE:	POLYAMIDE
LEVERS:	STAINLESS STEEL

PIC RATINGS/SPECIFICATIONS	
NEMA/UL EN 60529:	4, 4X, 12 IP65
MOUNTING SCREW SIZE:	M4 (8-32) (304 or 316SS for 4X)
MOUNTING SCREW TORQUE:	1.2~1.8N-m (0.9~1.3 Lb-Ft)

MOUNTING KIT ORDERED SEPARATELY CONTAINS M4x0.7 SS SCREW, NYLON WASHER, SPLIT LOCKWASHER AND M4 NUT
P/N: D-PIC-MT



UNLESS OTHERWISE SPECIFIED:

DIMENSIONS ARE IN INCHES AND [MM]

MATERIAL
FINISH
DO NOT SCALE DRAWING

DRAWN BY:	DCG
DRAWN DATE:	06/24/2019
CHECKED BY:	GO
CHECK DATE:	06/24/2019

MENCOM CORPORATION
TITLE:
DB25-RJ45-2DB9-32

STANDARD CONFIGURATIONS UNLESS OTHERWISE NOTED		
CONN. TYPE	EXTERIOR	INTERIOR
RJ45	CAT. 6 JACK	CAT. 6 JACK

COMMENTS:

SIZE	DWG. NO.	REV
B	DB25-RJ45-2DB9-32	B
SCALE: 2:3	WEIGHT:	SHEET 1 OF 1

8 7 6 5 4 3 2 1