

8 7 6 5 4 3 2 1

D
C
B
A

D
C
B
A

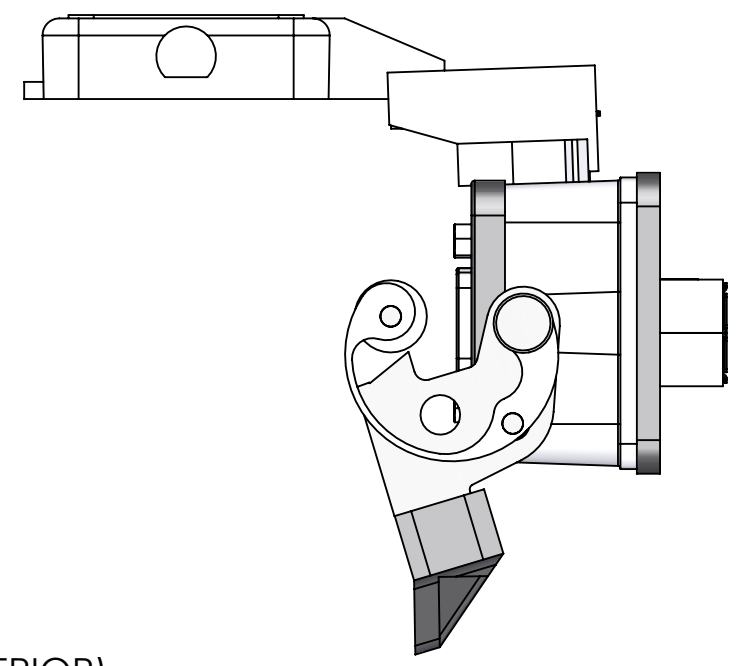
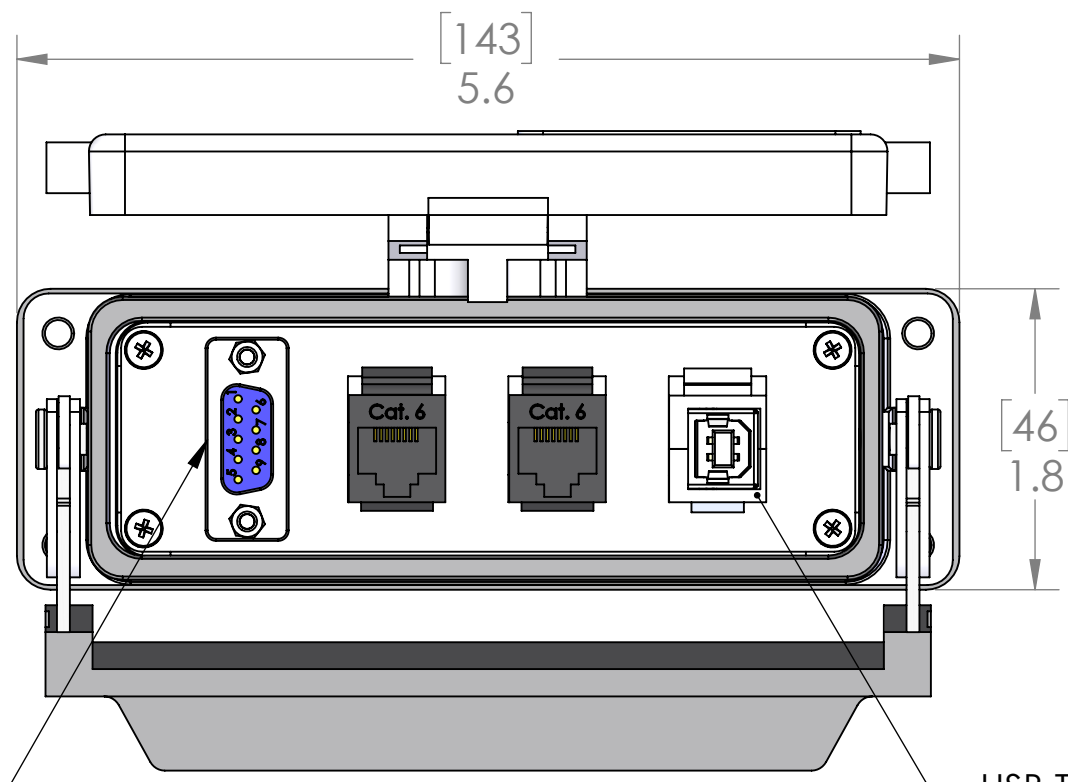

9 PIN D-SUB

USB TYPE B FEMALE (EXTERIOR)
TO TYPE A FEMALE (INTERIOR)

PANEL CUTOUT

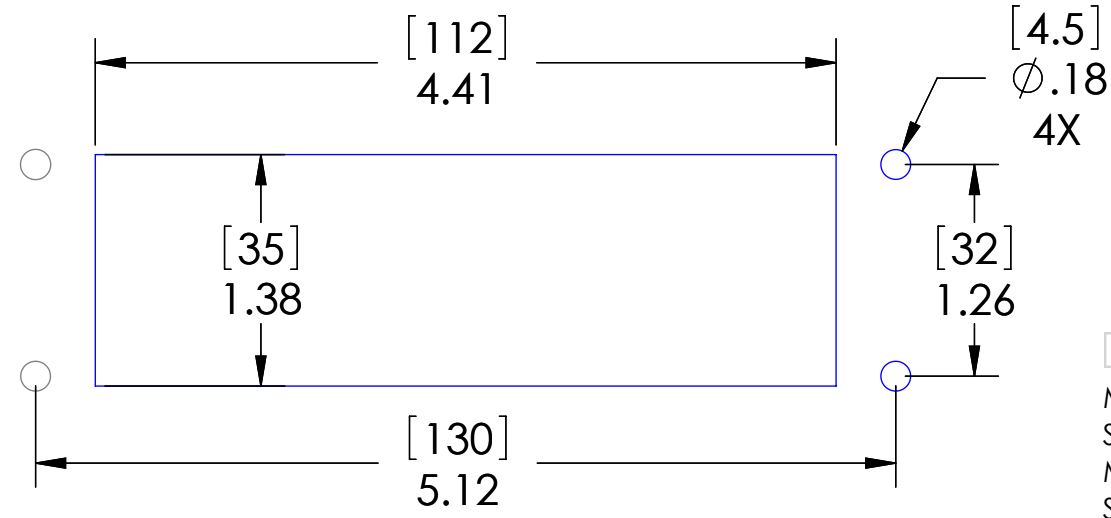

These devices shall be mounted on enclosures having adequate strength and thickness and with adequate spacing provided. Seal rating is based on mounting to a surface that is clean, flat and smooth.

HOUSING MATERIALS	
BODY:	EPOXY COATED DIE CAST ALUMINUM
GASKET:	THERMOPLASTIC ELASTOMER
HANDLE:	POLYAMIDE
LEVERS:	STAINLESS STEEL

PIC RATINGS/SPECIFICATIONS	
NEMA/UL EN 60529:	4, 4X, 12 IP65
MOUNTING SCREW SIZE:	M4 (8-32) (304 or 316SS for 4X)
MOUNTING SCREW TORQUE:	1.2~1.8N-m (0.9~1.3 Lb-Ft)

OPERATING TEMPERATURE: (-10°C / +60° C (+14° F / +140° F))

MOUNTING KIT ORDERED SEPARATELY CONTAINS M4X0.7 SS SCREW, NYLON WASHER, SPLIT LOCKWASHER AND M4 NUT
P/N: D-PIC-MT



UNLESS OTHERWISE SPECIFIED:	
DIMENSIONS ARE IN INCHES AND [MM]	
MATERIAL	
FINISH	
DO NOT SCALE DRAWING	

DRAWN BY	DG
DRAWN DATE	07/13/2021
CHECKED BY	DCG
CHECK DATE	07/15/2021

MENCOM CORPORATION
TITLE:
DB09; 2RJ45; USB-BA; 24

STANDARD CONFIGURATIONS UNLESS OTHERWISE NOTED		
CONN. TYPE	EXTERIOR	INTERIOR
RJ45	CAT 6 JACK	CAT 6 JACK
ALL D-SUBS	FEMALE	MALE

SIZE	DWG. NO.	REV
B	DB09-2RJ45-USB-BFAF-24	C
SCALE: 7:8	WEIGHT:	SHEET 1 OF 1

8 7 6 5 4 3 2 1