

“Stay Connected” with



Power Components

a PennEngineering® Company

Heyco® Turn-2-Lock Cordset Contacts

For Finished, Custom Turn-2-Lock Cord and Plug Sets, see section 9
20 Amp



Type	PART DATA		PART NO.	APPLICATION TOOLING*				
	AWG Range	Material		Die**	Feeds	Tool Packs	Crimp Punch	Anvil
Male - for snap together Male Nylon Premold Bridges see page 8-20								
TL-L5-20-W†	16-10	Brass	6114	6114UXX5	Bulk	B958/B959	C663	C667
TL-L5-20-B†	16-10	Brass	6116	6116UXX5				
TL-L5-20-G	16-10	Brass	6118	6118UXX5				
TL-L7-20-G	16-10	Brass	6132	6132UXX5				
TL-L24-20-G	16-10	Brass	6138	6138UXX5				
Female - for snap together Female Nylon Premold Shells see page 8-20								
TLR-L5-20	16-10	Brass	7552	7552UXX5	Left to Right	B972L/B973	C784	C783

* Use the Heyco Universal Applicator Die (indicated by “U” in the Die Part No.), page 8-59.

** “XX” represents Wire Gauge. Please specify Wire Gauge when ordering.

† Can be used for L7 and L24 configurations.

- Easy loading for increased molding efficiency.
- Use inexpensive Heyco load pins (consult Heyco for details on our complete line of blades and pins).
- Reduce PVC usage and allow more cavities per mold.
- All Ground blades feature 90° leg for twist-locking mechanism.
- .056” gauge material, cut-out shapes and radius are all UL Specified.
- DFARS Compliant

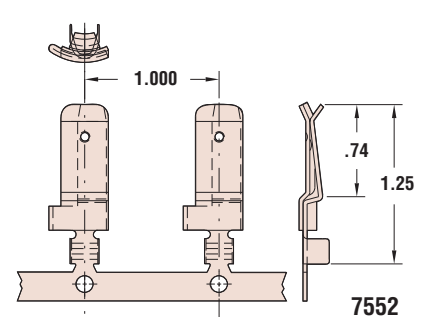
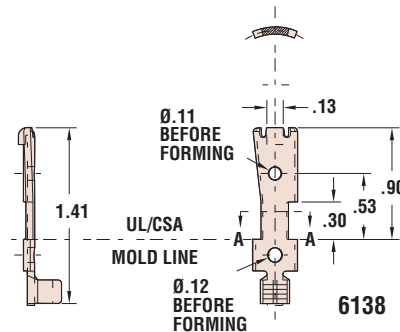
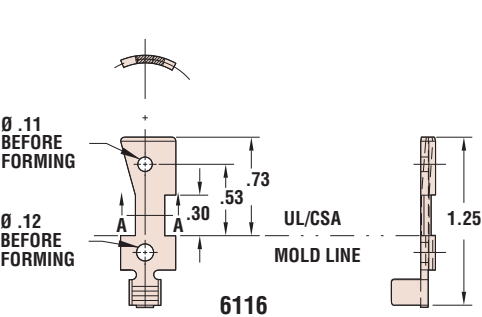
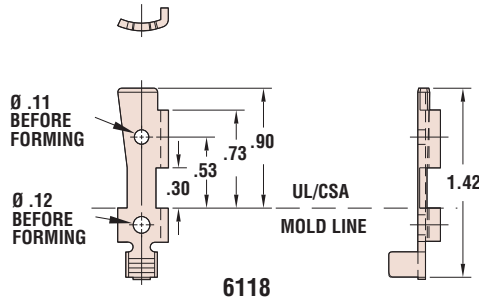
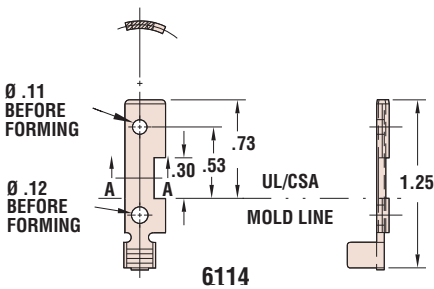

Materials Alloy 260 Brass (70% Cu, 30% Zn. Higher Cu content resists dezincification)
6/6 Nylon

Quick Specs